



SOLLATEK AVR

AUTOMATIC VOLTAGE REGULATOR

SOLID-STATE STABILISATION
FOR ALL INDUSTRIAL, PROFESSIONAL
AND DOMESTIC APPLICATIONS

Sollatek[™]
the power to protect

Contents

Company profile	3
Introduction	4
Single Phase - 250VA to 2500VA	6
Single Phase 4.5kVA to 90kVA	8
Three Phase up to 140kVA	10
Three Phase from 160kVA to 2MVA	12
General arrangement diagrams	14
Three Phase AVR with isolating transformer	16
Telecom Power Manager (TPM)	18
Three Phase options	20
Principles of operation	20
Technical notes	21
Specifications	23

Company profile

A leading force

Established for over thirty five years, Sollatek is a manufacturer of innovative products in power control, energy saving, temperature control, and solar energy. With its head office in the United Kingdom - where engineering, production, sales, marketing and logistics are located - Sollatek has a network of partners across the globe.

The Sollatek network comprises local Sollatek companies (with service centres) in over ten countries and distributors and resellers in over a further thirty countries. We work closely with our partners around the world to deliver our promise of a two year worldwide warranty, and in some local countries this is further extended to a five year warranty.

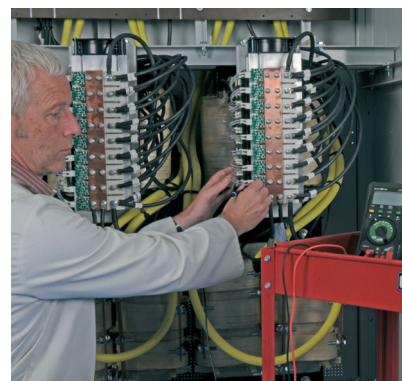

AVR Introduction



Stable power you can depend on

By using microprocessor and solid state technology, Sollatek AVRs can rapidly correct voltage variations and output a steady supply to your load equipment with an accuracy of better than $\pm 5\%$; far exceeding EU regulations.

The Sollatek units boast a very wide input voltage range (up to $\pm 35\%$) and have a voltage correction speed of 1250 V per second. SCADA and remote interface options are available.

Sollatek is a world leader in the field of voltage regulation and protection.

Wherever mains supply is erratic and unreliable, Sollatek has the ideal solution to protect all your domestic, commercial and industrial installations. And enabling your appliances to operate efficiently, wherever you are in the world.

From small domestic appliances (250VA) to large applications (500kVA), Sollatek can provide you with a solution. With single and three phase applications available, the Sollatek range of voltage regulators is your answer in the most unstable of power conditions.



The AVR is specified and used by a number of large organisations including:

- Satellite operators
- Infrastructure telecom companies
- Embassies worldwide for reliable electrification of their posts
- Medical systems for digital imaging, scanning and X-ray equipment
- Mobile phone operators
- Grid utility companies for voltage regulation to their sub-stations
- Various United Nations divisions including WHO, UNICEF and WFP
- Optional equipment includes:
 - Digital display: input and output voltage, output current
 - Manual bypass switch transferring the load to the utility grid
 - Input circuit breaker
 - Output circuit breaker
 - DSP class I and II (optional)

Practical and useful features

- Fully electronic with no moving parts for:
 - High reliability
 - Speed of operation
 - Immunity to dust and other environmental conditions
- Microprocessor controlled - high speed response.
- Wide input frequency tolerance between 45 to 75 Hz allowing unit to function properly in areas of severe voltage disturbances
- High overload capability with up to 150% for 4 minutes
- Very low losses and minimal heat dissipation due to an efficiency of over 96% at full load
- Internal automatic bypass (larger units)
- All cables made into LSZH compliant materials (low smoke zero halogen)
- Galvanised steel construction with high anti-corrosion paint finish
- Warranty of 2 years. Sollatek provides full back up support on all its products, with local support in over 20 countries worldwide

Single phase - 250VA to 2500VA



Introduction

Suitable for all applications for domestic and small office use, this range of AVRs is built into an attractive and modern enclosure to suit and blend with modern equipment.

The Sollatek AVR range from 250VA up to 2500VA is built into a strong, plastic enclosure (see table opposite for dimensions). The larger units are built into a metal enclosure with a plastic fascia, providing a smart unit that will blend well with other equipment.

Features

LED display - A 17 Light Emitting Diodes (LED) display is built on the front panel. This display provides the following indications:

Input Voltage - 7 LEDs indicate the state of the incoming voltage. At a glance it is possible to see the level of under-voltage or over-voltage.

Output Voltage - 5 LEDs indicate the state of the output voltage. A 0% indication shows the output voltage reaching your equipment is at the correct nominal voltage.

Load Current - 5 LEDs display the percentage of rated current the load is drawing through the AVR. Although the Sollatek AVR will withstand 110% overload for long durations, it is never recommended to overload any equipment. The overload indication makes it possible to reduce the load, allowing the AVR to work safely. If the overload persists then the Sollatek AVR will disconnect the load for protection.

Front displays

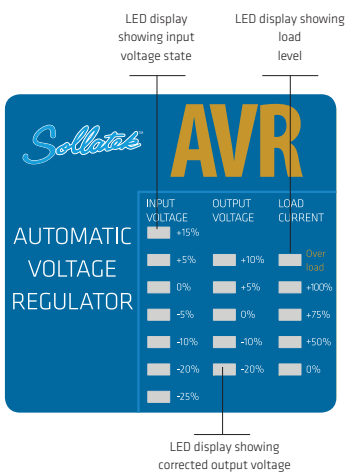
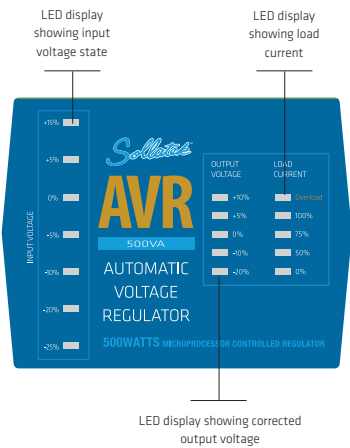

Rear panels

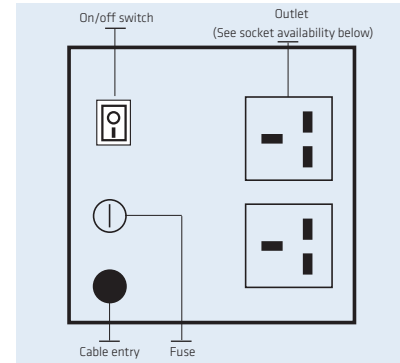
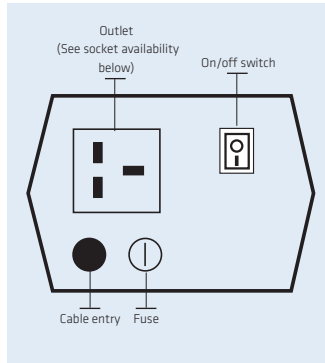

Socket availability

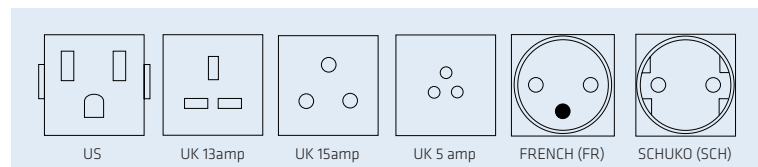

Any of the above sockets types can be ordered on the rear panels

Specifications

Model	Amps	Voltage	VA	Socket	Weight (kg)	Dims (mm)	Case material	Case type
AVR01-22	1	230	230	UK,FR,SCH,UK5	4	124 x 193 x 100	Plastic (ABS)	A
AVR02-22	2	230	460	UK,FR,SCH,UK5	5	124 x 193 x 100	Plastic (ABS)	A
AVR05-22	5	230	1150	UK,FR,SCH,UK15	12	145 x 285 x 212	Metal	C
AVR10-22	10	230	2300	UK,FR,SCH,UK15	15	179 x 335 x 212	Metal	D

Single phase 4.5kVA to 90kVA



AVR300-22



AVR100-22 with digital display

Introduction

Suitable for large applications covering a small office to an entire apartment, a house or even a small workshop.

Available from 4.5kVA (at 230V supply) up to 100kVA (260 Amps at 230V) and built into a tower metal enclosure with a small footprint of 215x347 mm (for models up to AVR40-22). Included as standard, this range of AVRs includes an LCD which provides input voltage,

output voltage and output current monitoring. Using state of the art technology the Sollatek AVR displays load current in real time, input voltage and output voltage (the display toggles between input and output voltage, using a switch).

Front display

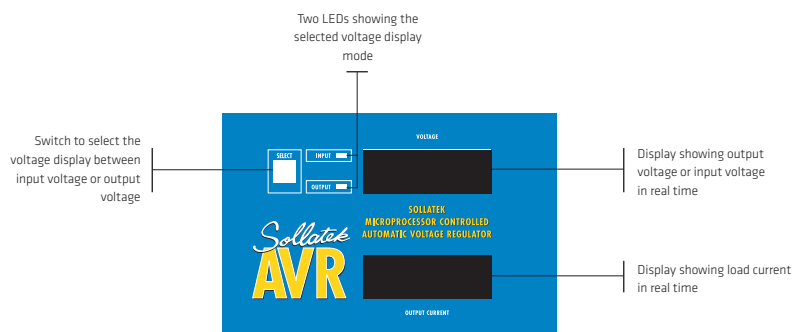

Front panel AVR20, AVR30, AVR40



For AVR models up to 10kVA @ 230V (AVR40-22)

Specifications

Model	Amps	Voltage	kVA	Weight	Dims (LxWxH)
AVR20-22	20	230	4.6	40	215 x 347 x 520
AVR30-22	30	230	6.9	55	215 x 347 x 520
AVR40-22	40	230	9.2	60	215 x 347 x 520
AVR50-22	50	230	11.5	82	460 x 785 x 445
AVR75-22	75	230	17.2	100	460 x 785 x 445
AVR100-22	100	230	23.0	114	460 x 785 x 445
AVR250-22	250	230	57.5	350	680 x 1200 x 1130
AVR300-22	300	230	69.0	382	680 x 1200 x 1130
AVR350-22	350	230	80.5	397	680 x 1200 x 1130
AVR400-22	400	230	92.0	423	680 x 1200 x 1130
AVR30-11	30	110	3.3	36	215 x 347 x 520
AVR40-11	40	110	4.4	40	215 x 347 x 520
AVR50-11	50	110	5.5	50	460 x 785 x 445
AVR75-11	75	110	8.2	56	460 x 785 x 445
AVR100-11	100	110	11.0	65	460 x 785 x 445
AVR250-11	250	110	27.5	127	680 x 1200 x 1130
AVR300-11	300	110	33.0	186	680 x 1200 x 1130
AVR350-11	350	110	38.5	204	680 x 1200 x 1130
AVR400-11	400	110	44.0	287	680 x 1200 x 1130

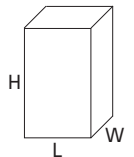

Three phase Up to 140kVA



Introduction

The three phase AVR is made up from three identical single phase regulator units. Each of these monitors its own output voltage and adjusts for variations in mains supply voltage. This will maintain an output voltage within close limits.

The standard Sollatek three phase AVR's all feature the same input voltage range as standard (-30% to +22%), making them ideal for all applications where the voltage supply is erratic. Also, when compared to stabilisers of the same input range, the Sollatek AVR is one of the most competitively priced units available.

Block diagram

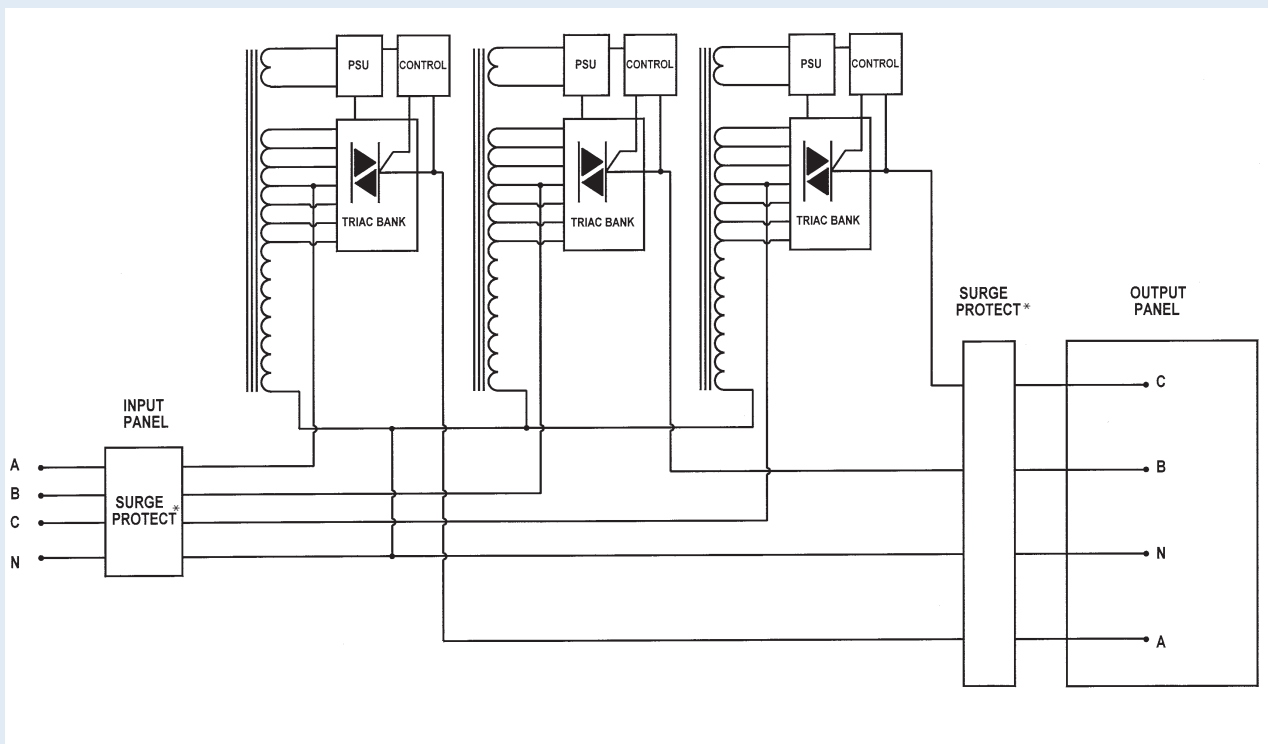

Block diagram of Sollatek Three Phase AVR

*optional

Specifications

Model	Amps per phase	Voltage	kVA	Weight (kg)	Dims (mm) W x D x H
AVR3x20-22	20	230/400	13.8	100	450 x 635 x 850
AVR3x30-22	30	230/400	20.7	150	450 x 635 x 850
AVR3x50-22	50	230/400	34.5	210	500 x 685 x 1060
AVR3x75-22	75	230/400	51.7	285	600 x 735 x 1110
AVR3x100-22	100	230/400	69.0	400	500 x 835 x 1280
AVR3x150-22	150	230/400	103.5	450	500 x 835 x 1280
AVR3x200-22	200	230/400	138.0	575	680 x 1200 x 2070

Up to 3000A per phase available

These are standard models.

Input range for the standard models is -30% to +22%.

Other models can be made to order.

To reduce cost and in areas of more stable input voltage, Sollatek can provide the M (AVRM) series with an input of +/-15%. The model number will be as above but with an M suffix.

E.g. AVRM3x20-22.

Ordering

The Sollatek three phase AVR range is easy to order. All units are rated by the number of AMPS per phase and the input/output voltage. For example:

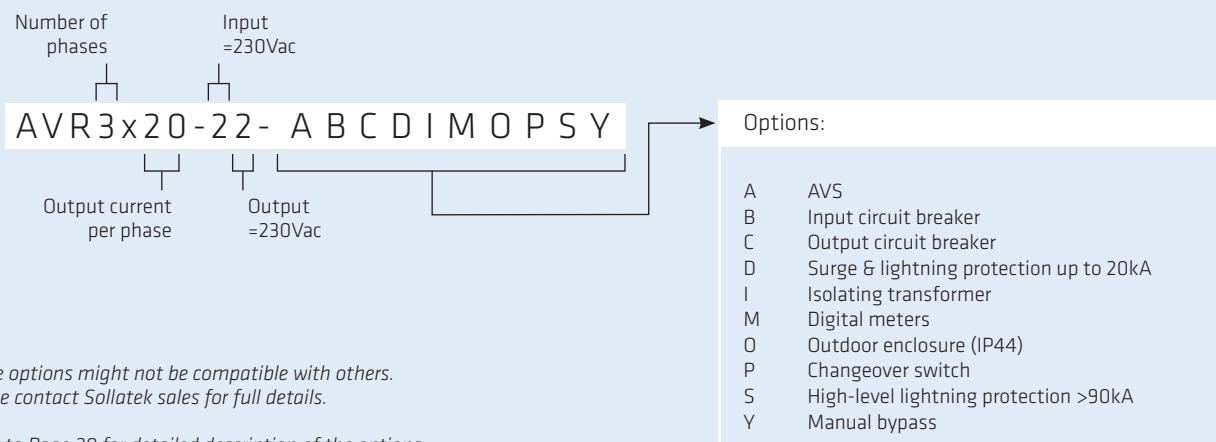

Some options might not be compatible with others.
Please contact Sollatek sales for full details.

Refer to Page 20 for detailed description of the options.

Three phase AVR

from 160kVA to 2MVA



Introduction

The high current Sollatek AVR range (>250Amps/phase) uses Silicon Controlled Rectifiers (SCR or Thyristor) technology. At higher currents, SCR technology provides ultimate robustness and efficiency of operation. They are more rugged and provide versatility during switching.

Furthermore, the Thyristor range of the Sollatek AVR has been enhanced with many features including auto-internal by-pass, remote monitoring options, and more efficient electronic designs, making

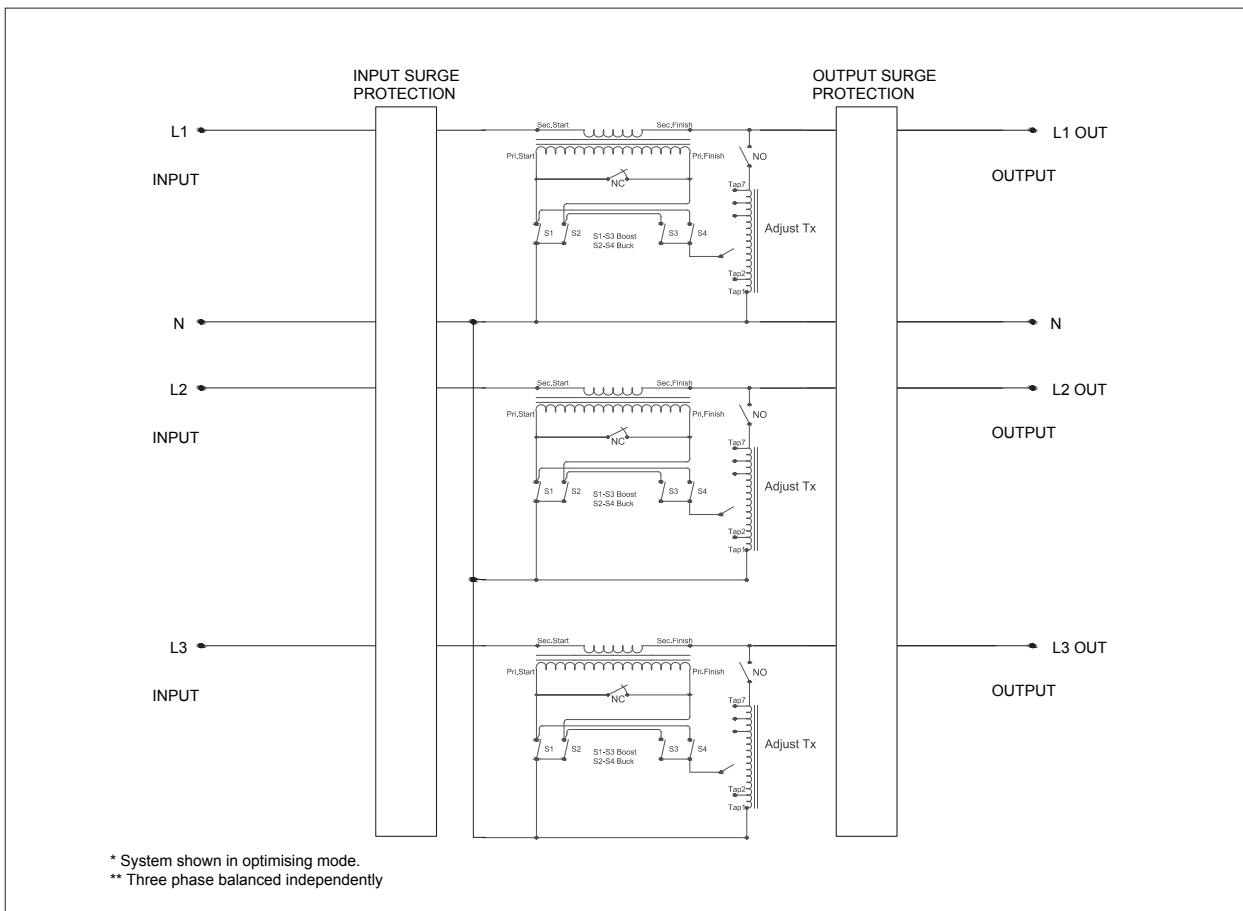

the unit simpler to install and more robust. The Sollatek SCR range is available as standard with an input range of $\pm 20\%$ and output accuracy of 3%. This is referred to as the S (Standard) range.

Further input tolerance models are available. In areas where fluctuations are not expected to be very wide, the N (Narrow) range provides $\pm 12.5\%$ input and a 3% output accuracy.

And where the mains is expected to vary in extreme, the E (Extended) range provides -30% to +20% input with a 4% output accuracy.

This will come at a higher cost and with a much larger footprint.



General arrangement diagram

(other variations available)

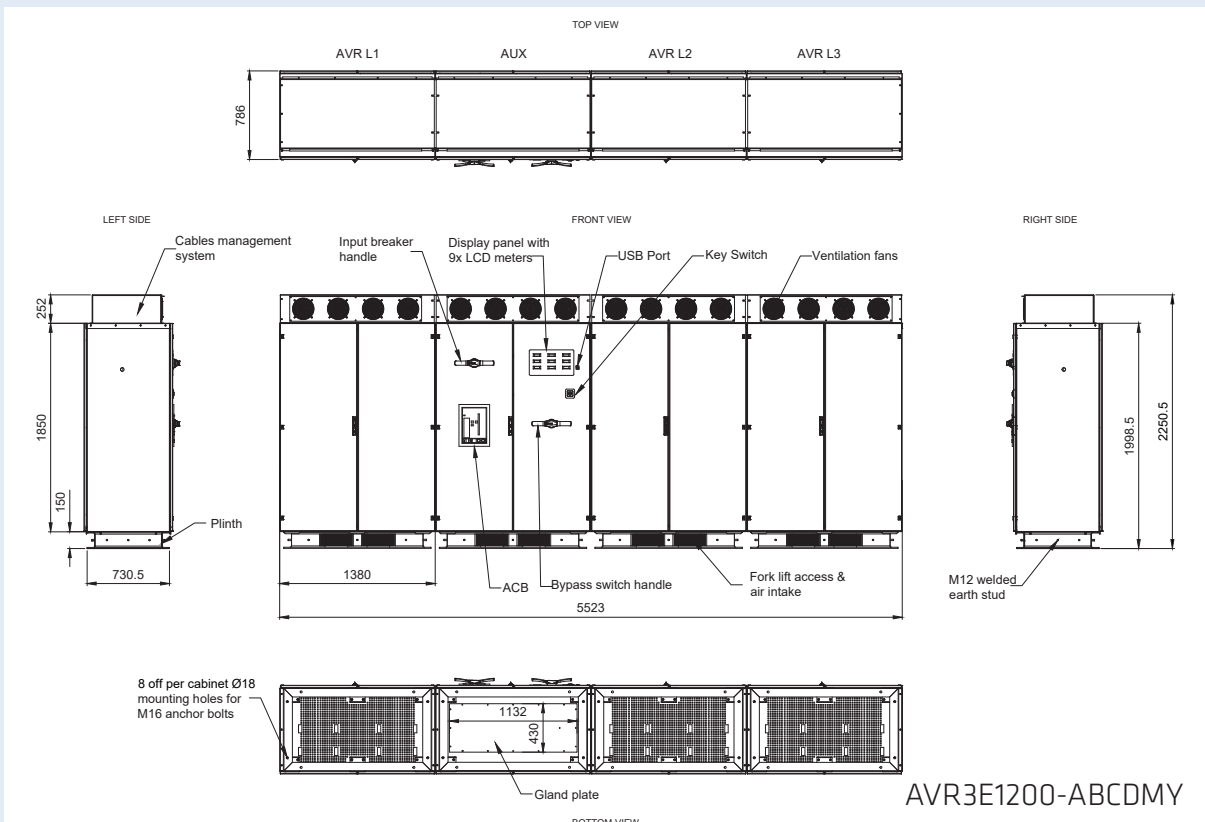
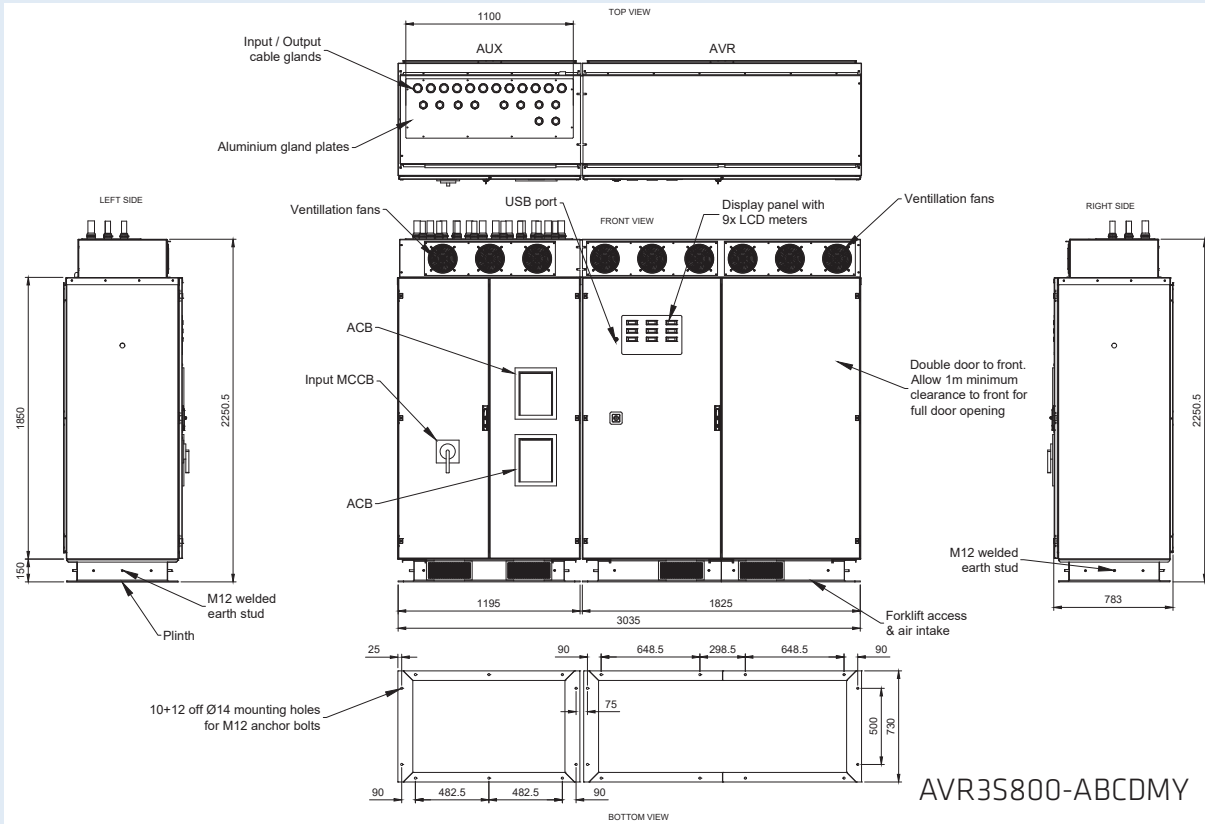

Models available for AVR3S

Thyristor Technology

Narrow (input $\pm 12.5\%$, output $\pm 3\%$)	Standard (input $\pm 20\%$, output $\pm 3\%$)	Extended (input -30% , $+20\%$, output $\pm 4\%$)
AVR3N250-DM	AVR3S250-DM	AVR3E250-DM
AVR3N300-DM	AVR3S300-DM	AVR3E300-DM
AVR3N400-DM	AVR3S400-DM	AVR3E400-DM
AVR3N500-DM	AVR3S500-DM	AVR3E500-DM
AVR3N600-DM	AVR3S600-DM	AVR3E600-DM
AVR3N800-DM	AVR3S800-DM	AVR3E800-DM
AVR3N1000-DM	AVR3S1000-DM	AVR3E1000-DM
AVR3N1200-DM	AVR3S1200-DM	AVR3E1200-DM
AVR3N1500-DM	AVR3S1500-DM	AVR3E1500-DM
AVR3N2000-DM	AVR3S2000-DM	AVR3E2000-DM
AVR3N2500-DM	AVR3S2500-DM	AVR3E2500-DM
AVR3N3000-DM	AVR3S3000-DM	AVR3E3000-DM

Ordering

The Sollatek three phase AVR range is easy to order. All units are rated by the number of AMPS per phase and the input/output voltage. For example:

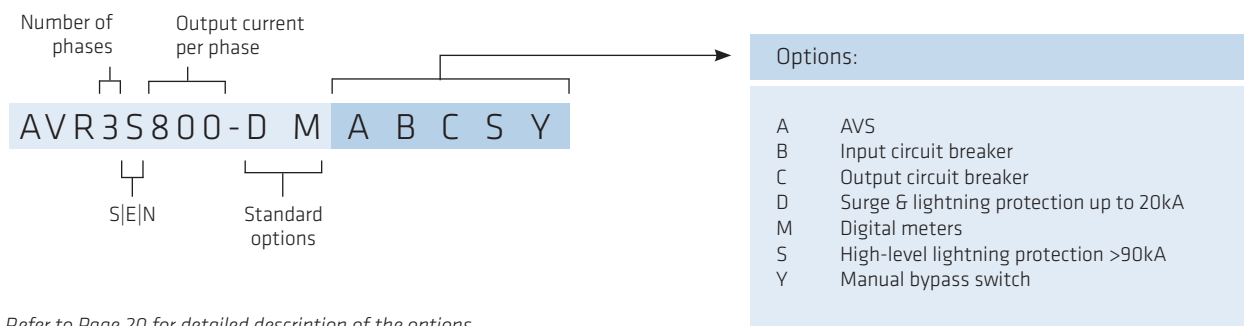

Refer to Page 20 for detailed description of the options

Three phase AVR with Isolating Transformer



16

Introduction

The Sollatek isolating AVR is a version of the standard Sollatek AVR. Designed specifically to provide the high level of protection required for telecommunication applications and for equipment that requires a higher level of surge, spike, and noise protection. Using an isolating transformer, the AVR provides a clean neutral and 10:1 attenuation ratio ensuring that noise on the output is significantly reduced relative to the input.

As the Sollatek isolating AVR requires no incoming neutral, it is protected against 'loss of neutral' problems. These can occur when the neutral connection is lost, either by damage or through the neutral cable being stolen and can result in voltage imbalance and damage in non-isolating regulators.

These models as standard include various additional features that are normally provided as optional extras. These include a higher IP rating of 44 to allow outdoor installation. The standard inclusion of output circuit breaker, manual by pass and automatic voltage switcher function all make this unit the preferred choice for mission critical applications.

Main features

- Designed for remote operation where a high degree of reliability is essential
- Input delta/star isolating transformer
- Weather-proof enclosure

Equipped with

- Bypass switch transferring the load to the utility grid
- Low and high voltage protection
- Surge and lightning protection
- Easy access cabinet with lockable doors
- Output circuit breaker

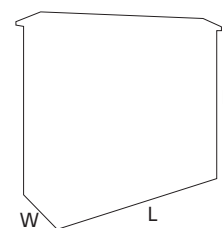

Specifications

Model	Amps per phase	Voltage	kVA	Weight	Dimensions (LxWxH)
Isolating AVR (I)					
				kg	mm
AVR3x12-22-I	12	230/400	8.3	150	700 x 930 x 1100
AVR3x20-22-I	20	230/400	13.8	230	700 x 930 x 1450
AVR3x30-22-I	30	230/400	20.7	325	700 x 930 x 1450
AVR3x50-22-I	50	230/400	34.5	375	700 x 930 x 1450
AVR3x75-22-I	75	230/400	51.7	475	700 x 930 x 1450
AVR3x100-22-I	100	230/400	69.0	620	900 x 1200 x 1750
AVR3x150-22-I	150	230/400	103.5	950	900 x 1200 x 1750
Isolating AVR - OUTDOOR (O)					
AVR3x12-22-IO	12	230/400	8.3	175	1110 x 370 x 1090
AVR3x20-22-IO	20	230/400	13.8	250	1110 x 450 x 1190
AVR3x30-22-IO	30	230/400	20.7	350	1110 x 450 x 1190
AVR3x50-22-IO	50	230/400	34.5	400	1110 x 450 x 1190
AVR3x75-22-IO	75	230/400	51.7	500	1310 x 650 x 1290
AVR3x100-22-IO	100	230/400	69.0	650	1310 x 650 x 1290
AVR3x150-22-IO	150	230/400	103.5	1000	1310 x 650 x 1290

Applications

- Satellite operators
- Infrastructure telecom companies
- Embassies worldwide for reliable electrification
- Medical systems for digital imaging, scanning and x-ray equipment
- Mobile phone operators
- Grid utility companies for voltage regulation to their sub-stations
- Various United Nations divisions including WHO, UNICEF and WFP



Telecom Power Manager (TPM) with Phase Selector



18

Introduction

The Telecom Power Manager (TPM) is an enhanced version of the Sollatek AVR and designed especially to provide the high level of protection and capability required for telecommunication applications.

With many telecom sites moving onto single phase power, the TPM uses the phase selector to allow for continuous voltage regulation even when 1 or 2 phases are missing. The isolating transformer provides a clean neutral and 10:1 attenuation ratio ensuring that noise on the output is significantly reduced relative to the input.

The TPM as standard includes various additional features that would otherwise be provided as optional extras. These include a higher IP rating of 55 (to allow outdoor

installation); output circuit breaker, manual by pass and automatic voltage switcher function all make this unit the preferred choice for mission critical applications.

Sollatek's wide input range and a high degree of reliability, makes the TPM the most appropriate solution for today's telecom's needs; whether in remote locations or city centres.

Features:

- Designed for telecom applications.
- Designed for remote operation where a high degree of reliability is essential.
- For areas where excessively low voltage is a major concern.
- Where loss of phase(s) is an issue.
- Fully electronic with no moving parts for:
 - High reliability
 - Speed of operation
- Immunity to dust and other environmental conditions.

Special features include:

- Wide input frequency tolerance between 45 to 75 Hz allowing unit to function correctly in areas of severe voltage disturbances.
- High overload capability with up to 150% for 4 minutes.
- Very low losses and minimal heat dissipation due to high efficiency design.
- Easy access cabinet with lockable doors.
- Provides a complete all in one solution for AC power to a site.
- Warranty of 2 years. Sollatek provides full back up support on all its products, with local support in over twenty countries worldwide.

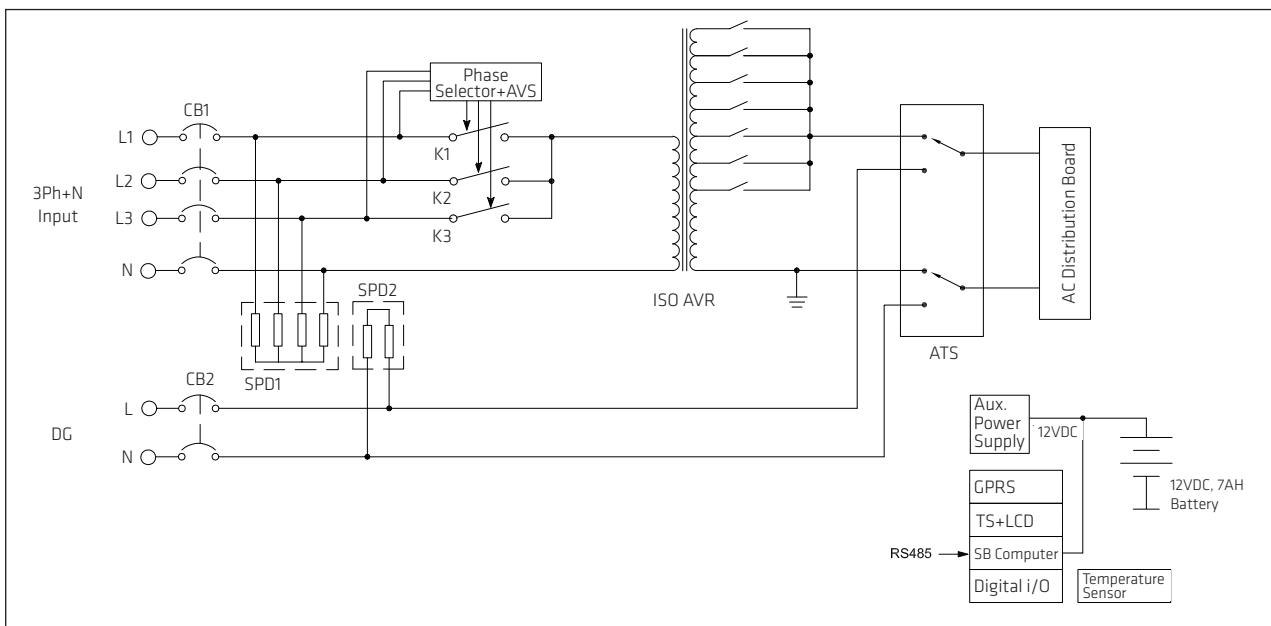

TPM block diagram

AVR options

A number of options is available on the Sollatek 3 Phase AVR range:

Option A: Automatic Voltage Switcher option (AVS™)

The AVS (a Sollatek UK Patent 2139436) option completes the protection that can be offered by the Sollatek AVR.

The AVS simply disconnects the mains when the voltage is 'BAD' and re-connects it automatically when the voltage returns to 'GOOD'. Using this principle, the AVS monitors the output of the AVR. If the AVR cannot correct the voltage sufficiently (in cases where the fluctuation is extremely high or extremely low), then the AVS will disconnect the output and thus provide this added protection to the appliance. When the AVR's output is acceptable, the AVS will monitor the supply for 1 minute to ensure stability and will then reconnect the mains.

The Sollatek AVS has an additional useful feature of Timesave™. Using its own microprocessor, the AVS will monitor the time. If the unit has been disconnected for more than 1 minute then the AVS will reconnect within 10 seconds.

Option B&C: Input/output circuit breakers

Circuit breakers protect the load and the AVR from the harmful effects of overcurrent. It is recommended that all Sollatek AVRs are installed with at least input circuit breakers and, wherever possible, output circuit breakers. These can be provided by the customer or alternatively, for ease of installation and for compactness, they can be ordered as an option to be built in to the AVR.

Option D&S: Additional surge/spike suppression - The DSP option

Extra surge/spike suppression is available on the Sollatek 3 Phase AVR range with the DSP. This will provide a high level of protection from lightning induced voltage and other voltage surges on the mains supply.

- Designed to handle surges of up to 20,000 amps
- Auto resetting
- Remote status indication via volt-free contacts
- Can be built-in or ordered separately in a plastic wall mounting enclosure
- Suitable for all current rating as the unit is shunt connected
- Peak surge current 20kVA
- Limiting voltage 750V
- Multiple discharge current 20 shots @ 10kA
- Filtered option attenuation 65dB @ 10 Mhz

Option I: Isolation transformer

Option M: Digital input/output voltage and current meters.

The Sollatek 3 Phase AVR can be ordered with meters to indicate the state of the input voltage to compare it with the output voltage. Current meters are useful to ensure that the load does not exceed the rating of the AVR.

Option O: Protecting the AVR against outside elements. Rated at IP 44

Option P: Changeover switch

Manual switch that will by pass the incoming mains from the AVR directly to the load. The AVR will remain powered on. To take the AVR off-line for maintenance, the system will need to be powered down first.

Option Y: Manual by-pass switch

The function of the bypass switch option is to allow the user to remove a regulator from service whilst the load remains connected to mains power. This has the benefit of allowing safe access to the AVR for servicing without having to disconnect power from the load, thereby reducing system downtime.

Principles of operation

AVR Function

This is based on an auto transformer with tap changing on the output. There are seven taps to each transformer giving an accurate output voltage for a wide range of input voltage. The taps are switched by generously rated Triac banks to cope with motor start loads.

This technique results in a voltage stabiliser which has no moving parts, responds quickly to voltage fluctuations and is not as large or heavy as other AVRs utilising different regulation techniques.

A micro-controller forms the heart of the control system. It measures the AVR output voltage and turns on the appropriate Triac bank to select the correct tap. A potentiometer is provided for fine adjustment of the output voltage. The micro-controller also measures the frequency of the mains supply and compensates accordingly. This also means that the AVR will work automatically over a frequency range of 45 - 75Hz and down to as low as 30Hz for short periods to help cope with diesel generator loading problems.

Frequency and voltage measurements are filtered by the circuit and software to remove noise and so prevent spurious tap changes. In an industrial environment there can be a large amount of electrical noise and interference present on the mains and load cabling. This may be caused by other equipment in the building such as electric motors and speed controllers, contactors and relays, electric welding, etc. This will distort the waveform of the electricity. To avoid this, spike suppressors are fitted to the AVR input and output to clip any high voltage transients on the line. Additionally, a capacitor type filter is fitted to the measurement input to the AVR to further attenuate spikes and to filter out high frequency noise and interference. As a further precaution, the software programme in the micro performs mathematical filtering using various averaging techniques. The software does a number of checks to ensure that the measurements it is getting are reasonable and consistent. All of these aspects of the design result in an AVR which is rugged and will perform well in an industrial environment.

Zero-Voltage Switching

The AVR uses an auto transformer with tap changing to regulate the supply. The taps are selected using triacs which are controlled by a microcontroller. The micro measures the voltage of the mains waveform many times in every cycle to determine the voltage and decide which tap to select. The micro also uses these measurements to synchronise the running of its software program to the mains wave-form. When a tap change is necessary, the micro watches for the mains voltage to reach zero volts and then it turns off the present Triac and turns on the new Triac. The micro and the triacs are semiconductor devices and switch very fast so that there is no interruption in the supply. This means that the new Triac is now in operation, selecting the new tap, at the very start of the next half cycle of the mains wave-form. The AVR will continue with this tap selected until the measurements by the micro determine that another tap change is necessary.

Zero-Voltage Solid State Switching is also superior to Relay/Mechanical based switching as it avoids interruption to the supply and also superior to servo based switching which apart from slow response and requiring maintenance, produces noise as the motor brushes move during correction.

Spike Protection

The Sollatek AVR is protected against spike and surges primarily by large Metal Oxide Varistors fitted at the input to the unit (260 Joules - 350VAC). These are fitted between the three lines and neutral and between the three lines and earth. These have the combined function of protecting the AVR and the load.

There is also a further Metal Oxide Varistor (1.5Joule - 31VDC) on each circuit board to protect the AVR's low-voltage circuitry. Polyester capacitors are fitted to all power supplies within the unit to filter out interference.

Technical notes

In most applications, purchasing a stabiliser is simply a process of deciding the power requirement and the voltage and choosing a suitably rated unit.

However, ambient temperature, altitude, load duty cycle, type of load are also all important factors in deciding which AVR to buy. Furthermore, in certain situations it can be necessary to consider in greater detail the characteristics of the electricity supply and connected load when selecting an AVR. Please see the notes below for further details:

Ambient Temperature. Ambient temperatures in excess of 40°C should be mentioned at the time of ordering as AVR size or rating may be affected. As a rule of thumb, output power should be de-rated by 10% - 15% per 10°C above 40°C ambient.

Supply Frequency. The Sollatek standard ranges of AVRs are suitable for both 50Hz and 60Hz supplies. However, frequencies below 50Hz result in larger transformer and therefore AVR size, while frequencies above 50Hz may enable AVR size to be reduced. Any frequency other than 50Hz should be notified at the order/enquiry stage.

Duty Cycle. If the AVR is to be used continually for considerably less than 100% of the time, allowance can be made for this, leading to a reduction in transformer size. The effective power in VA may be estimated from the following formula:

$$\text{Effective VA} = \sqrt{\frac{\text{Time on (mins)}}{\text{Total Time (mins)}}} (I^2) \times \text{Volts} \times 3$$

Time on = time in minutes that AVR supplies current (say 15 minutes)
Total time = total length in minutes of period in question (say 60 minutes)

I = Output current (say 20A)

In the above example, the AVR supplies 20 Amps for 15 minutes out of every 60 minutes. Duty cycle information may result in cost reduction and should be notified at the time of enquiry/order.

Operation at Altitude. The operation of electrical equipment at high altitude causes cooling by the circulation of air to be reduced. The greater the altitude the greater this effect. It is therefore important to indicate that the AVR is destined for a high altitude environment at the time of ordering. In this case, a high altitude is regarded as above 1500m.

Motor Starting. Motor loads draw a very high initial starting current from the AVR. Whilst the AVR is designed to be able to supply this initial high current without damage, repeated motor starts within a short period may cause excessive heating in the AVR. If motor based, air conditioner or refrigeration equipment are likely to constitute a large proportion of the AVR load, this should be indicated at the point of enquiry. Since this could result in an increase in AVR size, it may be beneficial in some instances to fit a soft start device to the motor to reduce starting surges. Please contact customer support at Sollatek UK or your nearest Sollatek agent for further advice.

Neutral. The Sollatek 3 phase AVRs MUST have a fully rated neutral connection to the supply.

Harmonics. It is important to state whether harmonics will be present on the supply, or will be generated by the load. Harmonics can be created by devices such as thyristors, silicon controlled rectifiers, switch mode power supplies, computer, UPS, television loads, fluorescent lamps with electronic ballasts, variable speed drives and welding equipment. Alternatively harmonics can be generated from the supply side by neighboring installations. If you think harmonics are present on the supply please contact customer support at Sollatek UK or your nearest Sollatek agent for further advice.

Circuit Breakers. As a minimum, the mains input to the AVR should be protected by a circuit breaker. For full protection an output circuit breaker should also be fitted. The input circuit breaker should be rated at 1.4 x output current. The output breaker should be rated at output current. The Sollatek AVR - single phase models - are all protected by either a fuse or circuit breaker. Circuit Breaker is an option on the three phase models.

Spike Protection. The AVR is protected against high voltage surges and spikes on input and output by metal oxide varistor based surge suppressors. Spikes can be caused by lightning, switching heavy reactive equipment such as industrial motors and transformers, arc welding and electrical grid switching. In areas of extremely high spike activity, additional protection may be necessary. Please contact customer support at Sollatek UK or your nearest Sollatek agent for further advice.

Cable selection. When selecting cable for the AVR input / out connections, one should bear in mind the input current may be up to 40% higher than the output current of the unit. The input neutral (4-Wire system) must be fitted and be fully rated. Voltage-drop should be kept as low as practicable.

Marine Shore Power. Sollatek Isolating AVR (voltage stabilisation and corrosion prevention).

Non isolated shore power supplies will quickly corrode marine vessels sacrificial anodes. Without these anodes severe damage will be caused to the vessels immersed metallic parts.

An isolating transformer type shore supply must be used to prevent this galvanic corrosion.

The shore supply is connected to the AVR transformer's primary winding, the AVR's secondary will be connected to the ship side mains input connector.

To prevent galvanic corrosion, the AVR's primary and secondary earth connections are intentionally separated and for personnel safety the secondary neutral and earth must be connected together with an earth fault detector (GCFI or RCD sold separately).

The AVR electrical equipment is contained in an IP44 lockable enclosure (rain proof) but depending on proximity to the water, additional housing may be required.

Please contact Sollatek technical support for further details.

Input and output voltage response for standard models

		wake up voltage																							
		NOMINAL SET AT 230V																							
INPUT	0-118	125	135	145	155	160	165	175	185	195	205	210	215	220	225	235	240	245	255	265	275	285	295	305	315
OUTPUT	Off	173	185	200	213	220	226	221	234	228	222	228	233	239	225	235	221	226	235	225	235	242	251	260	268

		wake up voltage																							
		NOMINAL SET AT 220V																							
INPUT		132	135	145	155	160	165	175	185	195	205	210	215	220	225	235	240	245	255	265	275	285	295	305	315
OUTPUT		OFF	186	200	214	220	228	223	219	212	222	229	214	220	225	219	223	228	217	226	234	242	251	260	268

AVR input and output voltage ratios

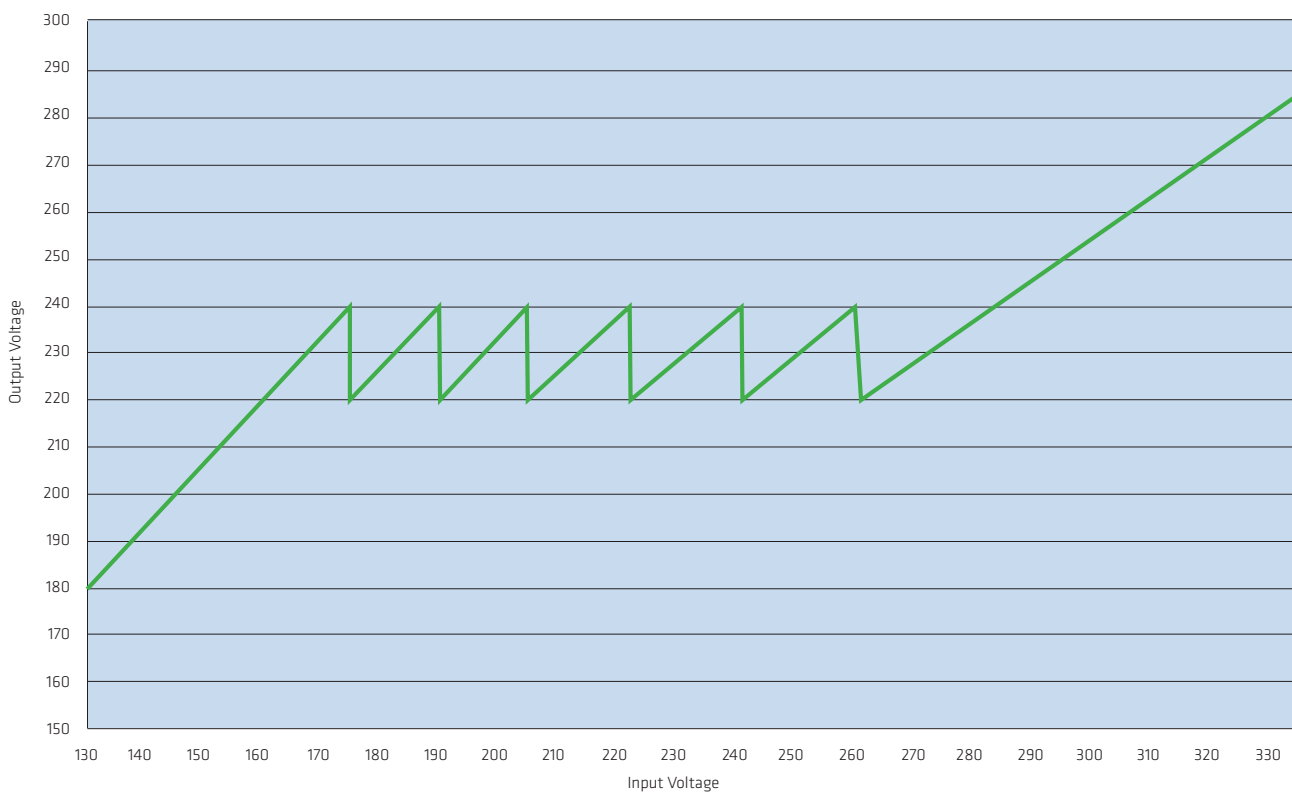

Voltage diagram for the Thyristor AVR (Standard Model, $\pm 20\%$)

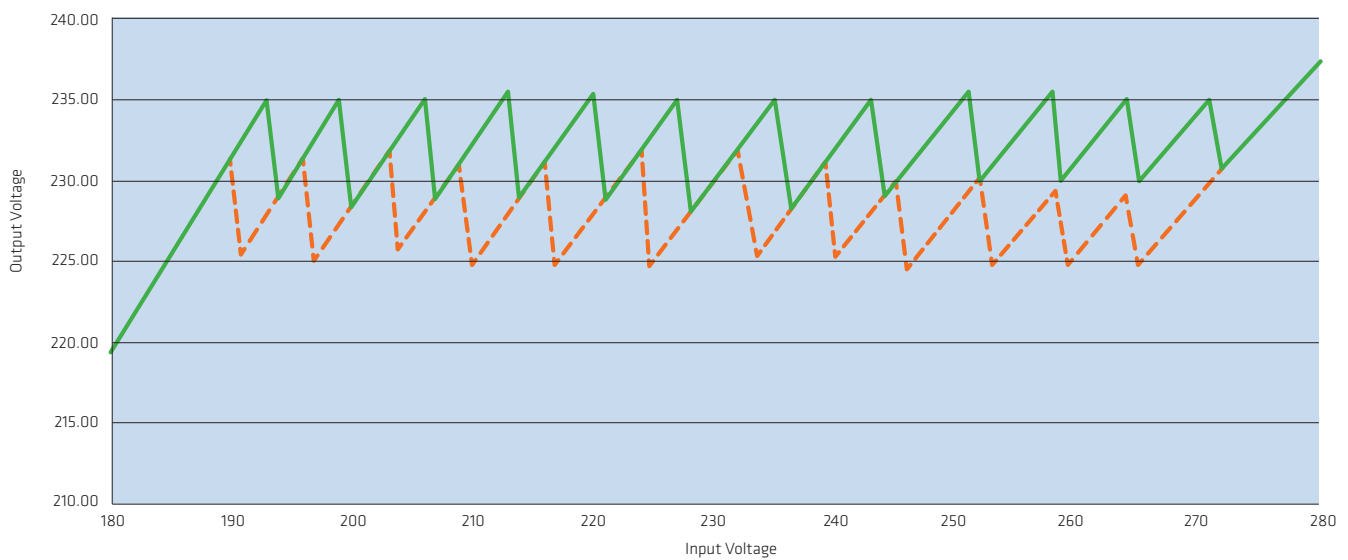

Specifications

	Up to 140kVA	160kVA and above
Input		
Input voltage	230/400V, -30,+22%. (wider input range optional)	230/400V, $\pm 20\%$. (other input range available)
Frequency range	45Hz to 75Hz (i.e 50Hz -10%, +50%. or 60Hz -25%, +25%)	
Additional Voltage THD	<0.2% at input (tested at 100% linear load), (No PWM methods used)	
Maximum Input THD	Can withstand >10% THD from the supply	
Output		
Output voltage	230/400V $\pm 4\%$	230/400V $\pm 3\%$
Maximum Output Current	20-200A	250-3000A
Maximum Output Power	Subject to AVR	
Correction time	40 m sec (0 to 100% load)	
Additional Voltage THD	<0.25% at output (tested at 100% linear load), (No PWM methods used)	
Crest Factor	> 1: 3 permissible on load current (tested at 100% load)	
Synchronization	Output synchronized to input	
Permissible Overload	1000% for 100ms 150% for 4 minutes 110% for 10 minutes	
Load Types	Designed to run lighting, motors, battery chargers, communications equipment, office equipment, SMPS, air- conditioners, compressors, industrial machines, medical equipment and others. Suitable for all domestic, commercial and industrial sites	
General		
Technology	All solid state (static) switching	
Efficiency	>96% (at 100% linear load)	>98% (at 100% linear load)
Heat Dissipation	Dependent on load	
Control	Microcontroller based control system provides self checks, system integrity monitoring and diagnostic indicators	
Control Protection	Internal surge arrestors and filters in control circuit protect against disturbances. Filtering algorithms and fault tolerant software protect against disturbances and false measurements	
Power Connections	Supply phases, neutral and earth. Load phases, neutral and earth	
Surge Protection	Heavy duty input and output surge arrestors to protect against extreme surges and lightning on the supply. Dual mode. 9600 joules total	
Displays*	Digital display, per phase for input voltage, output voltage, output current and frequency	
Ambient Temperature Range	0 to +55°C	
Relative Humidity	>95%, non condensing	
Environmental Protection	IP21	
Acoustic Noise	< 45 dB (A)	
Expected Service Life	> 25 years	
Standards	Manufactured to comply with :- ISO9001:2000, CE, EN 50081-1:1992, EN 50082-1:1998, EN 55022:1998, EN 61000-4-2:1995/1998, EN 61000-4-3:1996, EN 61000-4-4:1995, EN 61000-4-5:1995, EN 61000-4-6:1996, EN 61000-4-11:1994, DD ENV 50204	
Weight	See tables	



23

Comparison chart

	Sollatek AVR range	Sollatek AVR3S range	Other relay based stabilisers	Servo /mechanical stabilisers	Benefits of Sollatek AVR
Microprocessor controlled	Yes	Yes	No/some	No	Reliable Accurate operation allows advanced functions
Relays	No	No	Yes	No	Faster connection than mechanical types Quiet. Low cost
Mechanical elements	No	No	No	Yes - uses motorised transformer to adjust output	No mechanical elements means no servicing or maintenance required. Extremely fast correction speed
Requires servicing /maintenance	No	No	No	Yes - especially in dusty environment	Low operational expenditure
Typical voltage input range	-30 to +22%	$\pm 20\%$ (Other ranges optional)	$\pm 15\%$	$\pm 12.5\%$	The wide range is ideal, and in some cases essential in countries with chronic mains supply problems
Typical voltage output range	$\pm 4\%$	$\pm 3\%$	$\pm 6\%$	$\pm 1\%$	$\pm 3\%$ / $\pm 4\%$ exceeds most international standards
Cost comparison (rated 1 to 4)*	3	2	4	4 (most expensive if same input range compared i.e $\pm 25\%$)	Value for money. Low total cost of ownership (TOC)

*4 = most expensive

Sollatek's **expertise** extends **worldwide** through **local networks**



Global and Local

With a customer base across the world and a local presence in more than 50 countries, Sollatek is able to provide support services wherever you are.



SOLLATEK UK LTD.

Tel: +44 (1753) 214 500

sales@sollatek.com
www.sollatek.com

Sollatek (UK) Ltd.
Sollatek House, Waterside Drive, Langley, Slough SL3 6EZ UK



A STAMP OF AUTHENTICITY



ISO9001: 2008 accredited company

All weights and dimensions are approximate. Specifications are subject to change without prior notice. ©Sollatek (UK) Limited 2012. All Rights Reserved. SOLLATEK and the SOLLATEK device are the trade marks of the Sollatek group of companies.



MJA	17.01.2018
-----	------------

Voltright AVR Brochure Jan 2018
SC: 00021711
AI: 10910001