



The Sollatek Three Phase Automatic Voltage Regulator (AVR) Isolating Indoor & Outdoor Versions

Instruction Manual



Issue: June 2019

Important: This manual contains important safety instructions.
Keep this manual handy for reference.

Table of Contents

SECTION	PAGE
1. Unpacking and Inspection	3
2. Installation	3
2.1 Safety	
2.2 Positioning	
2.3 Ventilation	
2.4 Cables and Terminations	
2.5 Circuit Breakers	
2.6 Incoming Connections	
2.7 Outgoing Connections	
2.8 Earth/Neutral Connections	
2.9 Rear Panel Layout	
2.10 Front Door Layout	
3. System Power-up	6
4. Functional Description	7
4.1 General Function	
4.2 Transformer Configuration	
4.3 AVR Function	
4.4 AVS Function	
4.5 Bypass Switch Function	
4.6 Surge Arrester	
4.7 Suppressor Boards	
4.8 Fuse Boards	
4.9 Ventilation Fans	
4.10 Output Circuit Breaker	
4.11 Digital Meters	
5. Maintenance	11
6. Trouble Shooting	12
6.1 Safety	
6.2 False Starting	
6.3 Shut Down	
6.4 Common Troubleshooting Problems	
6.5 Error Mode	
7. Parts Replacement Procedure	14
7.1 AVR On-site Repair Guide	
7.2 AVR On-site Test Procedure Following Maintenance/Repair	
8. Specification	22
Appendix 1: System Diagram	24
Appendix 2: AVR Fault Report	25

1. Unpacking and Inspection

It is possible that the unit will have sustained damage during transit. The following procedure should be followed immediately upon receipt of the unit.

- 1.1 **Crate/Packaging** - Check for transit damage.
- 1.2 **Cabinet/Casework** - Check for visible signs of damage to exterior panels, doors and fittings. If cracks, scratches or dents are visible there is a chance of internal damage. Particular attention should be paid to the terminal panel.
- 1.3 **Internal components - Unlock the door using the key provided. Inspect for damage to the transformers, PCBs and other components. All mountings should be tight and there should be no sign of movement of the transformers.**
- 1.4 **Internal wiring** - All wiring connections should be checked to ensure that transit vibration has not loosened screw terminals.

If inspection reveals problems in the above or other areas, the carrier should be notified as soon as possible in writing.

2. Installation

2.1 Safety

Under no circumstances should any work be carried out on the unit unless the supply is isolated. Only qualified electricians should work on the AVR and its installation.

2.2 Positioning

It is important to carefully consider the place chosen to site the AVR.

2.2.1 Positioning of Indoor Units

The unit should be sited on a firm, dry and level surface. A position allowing access on all four sides to permit preventative maintenance would be advantageous. As there are cooling fans mounted in the cabinets it is important that there should be adequate space around the unit. As a guide, a free space of at least 300mm should be left in all directions around the AVR. Keep the AVR away from sources of heat and excessive dust and dirt. It should not be positioned where it will be in direct sunlight.

2.2.2 Positioning of Outdoor Units

The unit should be sited on a firm, level surface. A concrete base is recommended. A position allowing access on all four sides to permit preventative maintenance would be advantageous. As there are cooling fans mounted in the cabinets it is important that there should be adequate space around the unit. As a guide, a free space of at least 300mm should be left in all directions around the AVR. Ensure cable routing to/from the AVR will not subject the cable to damage. Protect the AVR from possible damage from road vehicles. Do not site it close to exhaust outlets, rain water outflows or areas frequented by animals.

2.3 Ventilation

The unit should be positioned such that a free flow of air is available. It is especially important to ensure that cooling fan outlets are free from obstruction. A free space of at least 300mm should be left in all directions around the AVR.

Open the front door of the AVR and identify the power PCBs, ST221 or ST165. These have rows of triacs on heat sinks and resistors on sub-PCBs. A 'comb' shaped item is used to support these heat sinks during transit. Remove them before use so as to maximize air flow.

2.4 Cable and terminals

Before any connections can be made the incoming and outgoing cable sizes have to be selected and, on 200A units and above, the appropriate ring terminals fitted. (See Table 2.4.1). Cable size may be

selected using values of current given in table 2.4.1 bearing in mind the usual limiting factors such as volt drop, heating, etc. The appropriate breaker sizes are also given. Note that the input and output currents can differ by 40%. This means that a larger cable size may have to be employed on the

Output Amps/ph	kVA (415V)	kVA (240V)	Input A (Max)	Input MCCB	Output MCCB	Ring Size mm
10	7.2	4.2	14	16	10	8
20	14	8.1	28	32	20	8
30	21	12	41	50	32	8
50	36	21	69	80	50	8
75	54	31	103	100	80	8
100	72	42	138	160	100	8
150	108	62	207	200	160	8
200	144	83	275	320	200	16

Table 2.4.1 AVR Input and Output Ratings

2.5 Circuit breakers

The recommended input and output breaker ratings are given in table 2.4.1. Values not shown may be interpolated. Due to the fact that breaker ratings jump in large steps it is strongly recommended that adjustable trip level MCCBs are used. In this way a high degree of protection may be achieved. The input MCCB should be of a type suited for use with inductive loads (with a high initial surge current). The output breaker should be chosen to suit the nature of the load.

2.6 Incoming connections

The three incoming lines should be connected to the terminals marked R1 S2 T3 on the terminal panel in the section marked INCOMING MAINS. The incoming neutral is connected to the N terminal and the system earth is connected to the E terminal. N.B. The AVR must be supplied with an incoming neutral which should be fully rated. Care should be taken to ensure that all terminals are securely tightened. See photo 2.6.1. Note - cable access is from below to the rear on indoor units and via a gland plate at the bottom right on outdoor units.



Photo2.6.1 Terminal Arrangement

2.7 Outgoing connections

The three outgoing lines should be connected to the terminals marked R1 S2 T3 on the terminal panel in the section marked OUTGOING MAINS. The outgoing neutral should be connected to the N terminal and the load earth to the E terminal. N.B. All neutrals should be fully rated. Care should be taken to ensure that all terminals are securely tightened. See photo 2.6.1 Ensure phase rotation continuity from input to output.

2.8 Earth/Neutral Connections

The Incoming and outgoing earth terminals of the AVR are connected together and connected to the metal chassis work of the AVR. In the interests of safety, they must be connected to a good quality, low impedance site earth point. Customer should also note that, due to the isolating nature of these AVRs, the output phase and neutral connections are floating with respect to earth. Depending on the site electrical arrangement, it may therefore be required to connect the output neutral terminal to the earth terminal to reference the load supply to site earth.

2.9 Rear Panel Layout

Photo 2.9.1 shows a typical layout of the terminal board. This is very similar in both indoor and outdoor units, except for the cable entry points.

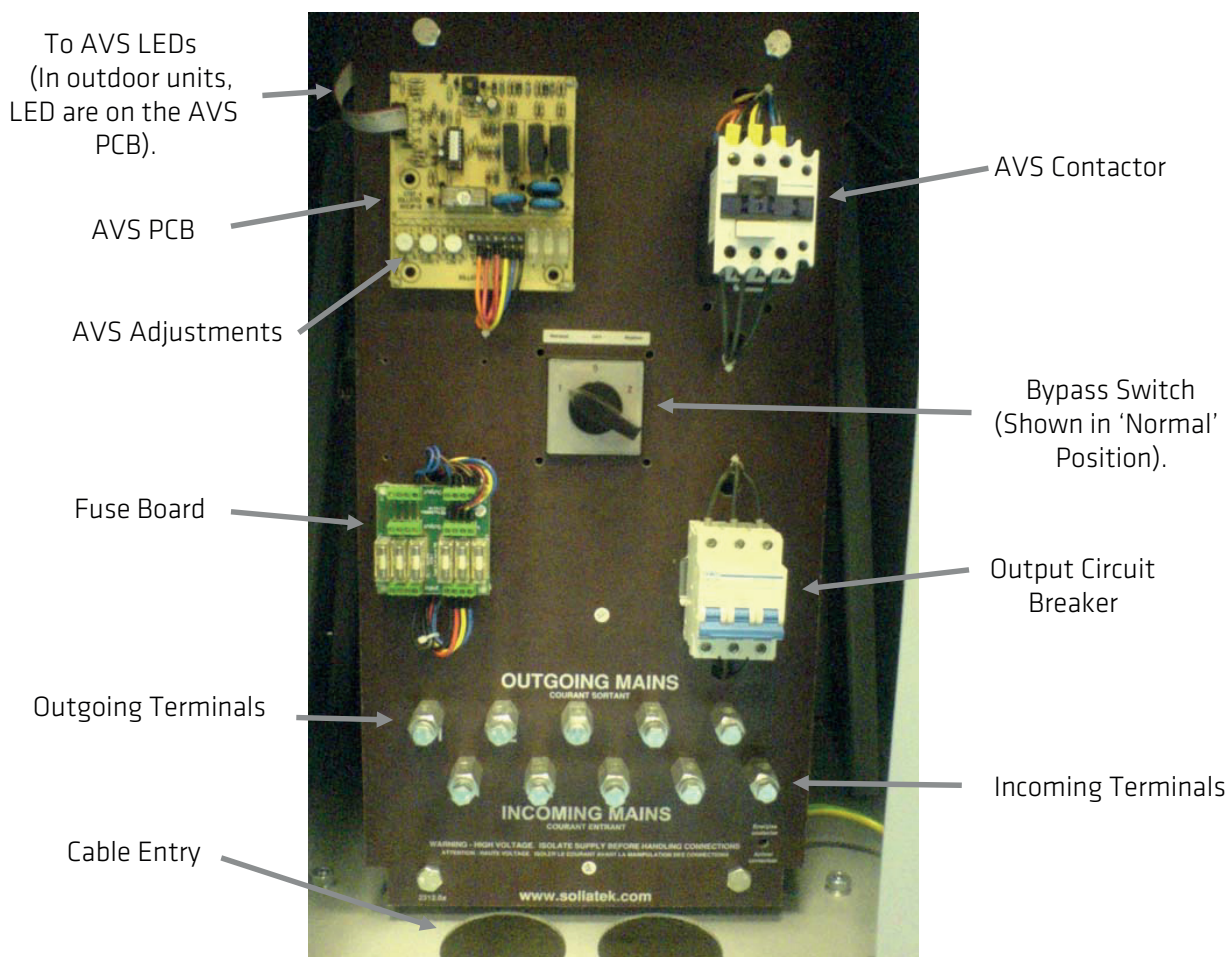

Photo2.9.1 Typical Isolating AVR Terminal Panel (Indoor Unit Shown)

2.10 Front Door Layout

Indoor Units - The AVS status indicators are situated on the front door, a set of five LEDs. See photo 2.10.1. The phase present indicators are to the right of the upper panel also shown in the photograph below.

Outdoor Units - The AVS indicator LEDs are inside the case on the AVS PCB, on the terminal panel. The phase presence indicators are also on the inside, on the ST221/165 power PCBs.



3. System power-up

Before the system is powered-up for the first time the following checks should be carried out by qualified personnel only.

1. Inspect the input and output terminations for tightness, correct wiring and phase rotation.
2. Check that the building electrical service is of sufficient capacity to supply the input current of the AVR, remembering that this can be 40% higher than the output current to the load.
3. Check building electrical service is of correct nominal voltage and wiring configuration and that main circuit breakers are suitable for the inductive/transformer nature of the load represented by the AVR.
4. Ensure that the load equipment is ready to be energised.
5. Set the Bypass switch to 'Normal' , position '1'.
6. Turn the AVR output circuit breaker to 'Off'.
7. Check the 'delay' setting on the AVS is set appropriately for the load, e.g. 30 seconds for electronic loads, 3 minutes for air conditioners/compressors.
8. Once the above conditions have been verified, input power may be applied to the AVR.
9. Once input power is applied, the AVR regulator boards should power up as shown by the three green LEDs on the front door (indoor units) or on the power boards (outdoor units).
10. The AVS will go into a wait mode (see section 4.5) for up to 3 minutes, depending on the AVS delay setting and on how long has elapsed since the AVR was last powered up. This will be indicated by a yellow LED on the AVS indicator LEDs.
11. At the end of the wait time the noise of the contactor engaging will be heard and power will be supplied to the output. Now turn on the AVR output circuit breaker to supply power to the load.
12. Check that power is reaching the load correctly.
13. Check that the AVR ventilation fans are all running, extracting air.

4. Functional Description

4.1 General Function

This three phase AVR is fitted with isolation transformers in a delta-star configuration. This provides and clean, isolated supply to the load with a 'new' neutral connection. The AVR is made up from three identical single phase regulator units. Each of these monitors its own output voltage and adjusts for variations in mains supply voltage so as to maintain an output voltage within close limits.

When the AVS function is fitted, the outputs from the regulator are connected through a contactor to the load. The contactor is controlled by a three phase Automatic Voltage Switcher PCB which monitors the AVR outputs. This connects the load only when all the phase voltages are within acceptable limits. There is a delay function in the AVS to prevent frequent switching of the load.

A change-over switch is provided to by-pass the AVR in the event of needing to perform maintenance on the AVR. The switch is usually kept in the 'normal' (1) position but can be set to by-pass (2) if needed. There is also a centre off position,. See notes on the by-pass switch regarding neutral connection before using the by-pass mode.

An output circuit breaker is provided to protect the AVR from overload current and short circuit loads.

Fans and thermal switches provide temperature control and protection. Filters, suppressors and fuse provide electrical protection.

4.2 Transformer Configuration.

These AVRs are fitted with isolating transformers, one per phase. These provide a high degree of isolation from input to output. They also greatly attenuate common mode noise from the supply and prevent it reaching the load.

The primaries are each nominally 415V rated and are connected in a delta configuration. In the indoor 30A AVR each primary is made up of two coils connected in series. See appendix 1 for the connection diagram. In the outdoor 30A, indoor 50A and outdoor 50A AVRs, the primaries are made up of two coils connected in parallel. The 12A and 20A transformers have single coils.

The secondaries are nominally 230V rated and are connected in a star configuration so as to generate a new neutral point. The secondaries are in fact made of two coils each connected in parallel.

A further advantage of the delta input configuration is that an incoming neutral connection is not required from the supply. Often neutral supply connection are poor or missing and this can cause damage to loads and regulators due to high phase to neutral voltages that result.

4.3 AVR Function

This is based on an isolating transformer with tap changing on the output. There are seven taps to each transformer giving an accurate output voltage for a wide range of input voltage. Table 4.3.1 below shows the ratios of the seven taps for each phase. The taps are switched by generously rated triac banks to cope with motor start and other high in-rush loads. Low value resistors are fitted with each triac to ensure that high currents are shared equally between the triacs within each bank.

Input Voltage: 415

Colour	O/P Ratio	L-N O/P Voltage
Violet	0.87	208
Blue	0.953	228
Green	1.035	248
Yellow	1.118	268
Orange	1.212	290
Red	1.318	316
Brown	1.423	341

Table 4.3.1 AVR Transformer Ratios

This technique results in a voltage stabiliser which has no moving parts, responds quickly to voltage fluctuations and is not as large or heavy as other AVRs utilising different regulation techniques.

A micro-controller forms the heart of the control system. It measures the AVR output voltage and turns on the appropriate triac bank to select the correct tap. A potentiometer is provided for fine adjustment of the output voltage. The micro-controller also measures the frequency of the mains supply and compensates accordingly. This also means that the AVR will work over a frequency range of 45 - 88Hz automatically and down to as low as 30Hz for short periods to help cope with diesel generator loading problems.

Frequency and voltage measurements are filtered by the circuit and software to remove noise and so prevent spurious tap changes.

A watchdog function is implemented in the micro controller. This independently monitors the operation of the micro-controller and its software. If it detects a malfunction, it will reset the micro and re-initialise the control system.

The low voltage DC supply to power the control circuit is generated from a small isolated winding in the main transformer for each phase. This is passed through temperature switches on the transformer coils so as to shunt the AVR down in the event of over heating. The low voltage supply is also protected by a fuse.

Additionally, a hardware reset circuit is included which monitors the supply rail for the control circuit. If the mains is so low that the control circuit will not function correctly, the monitor circuit will put the micro-controller into the reset state and turn off all triacs.

When the mains supply increases to a usable level, the monitor circuit will restart the micro and the system will re-initialise. This ensures an orderly and controlled restart from a brown-out or blackout condition. The circuit is designed with a large hysteresis so that the unit will not attempt to turn on again until the supply voltage is sufficient to withstand possible starting surges. This avoids the possibility of such a surge of current causing the supply to dip sufficiently to turn the unit off again.

Additional protection is provided by temperature sensors fitted to each transformer. If the AVR is used at full load and either the ambient temperature is excessively high or the ventilation grills have been obstructed, the temperature of the transformer may increase beyond reasonable limits. In such an event, the temperature sensor will disconnect the supply to the corresponding control board and thereby turn the output off. When the transformer has cooled sufficiently, the sensor will restart the AVR.

When restarting after the above condition the AVR may cause equipment to begin to operate suddenly. Steps should be taken to ensure that this does not expose persons to risk.

4.4 AVS Function [Optional - has to be ordered separately at time of purchase]

The Automatic Voltage Switcher (AVS) is a device for the protection of electrical equipment against fluctuations, interruptions and other abnormalities in the electricity mains supply.

The Three Phase AVS monitors various parameters of the mains supply, and keeps it connected to the equipment so long as all the parameters are within defined acceptable limits. This is the normal condition and it is indicated by a Green LED (light emitting diode).

If the mains voltage goes outside these limits, the AVS disconnects the equipment from the mains and this is indicated by the Red LED (In some options, it is possible to select indication only without disconnection's.)

When the mains supply returns within the acceptable limits, indicated by an Amber LED, the mains

remain disconnect from the equipment during the wait time, set to a nominal 1 minute by factory selected components. If during the wait time the mains again goes outside the limits, the wait time starts from the beginning.

At the end of the wait time, when the mains supply has been continuously within the limits for its duration, normal condition returns indicated by the Green LED, and the equipment is re-connected to the mains.

The parameters monitored by the Three Phase AVS are:

a) Value of the Mains Voltage

The normal condition is when the values of the mains voltage of all the phases are within certain preset limits referred to as the "window". The AVS detects when the voltage of any one or more phases goes outside the window, either over- or undervoltage.

b) Phase Relationship (timing)

The AVS monitors the phase relationship between the three phases of the supply. The normal condition is when the phase difference between the three phases is 120 degrees, corresponding to $T/3$ where T is the period of one cycle.

c) Phase Rotation [optional]

The AVS can detect a phase rotation error of the three phase mains supply. It will switch off if the phases are not in the correct order.

Detection of parameters c) above is not standard, but is obtained by an optional change of control chip.

The output of the AVS PCB is a single volt-free relay contact. This is used to control a contactor with rating to suit the output current rating of the AVR. It has three independent contacts sets, to switch the three phase lines of the AVR output.

4.5 Bypass Switch Function (Optional)

This is used to take the AVR out of circuit, bypassing the supply straight to the load. A fully rated, in line, mechanical switch is used to achieve this. This ensures that the supply to the AVR cannot be re-connected unintentionally by component failure or supply disruptions. This is particularly important if the bypass is used to enable maintenance to be carried out.

The bypass switch is a changeover switch with three positions. See diagram 4.5.1 below.

The '1' position is 'normal' and connect the supply to the input of the AVR while the AVR output passes through the output circuit breaker to the load.

The centre '0' position is an off function and disconnects the incoming supply from both the AVR and the load.

The right hand '2' position bypasses the AVR by disconnecting the supply from the AVR input and instead connecting the supply direct to the load.

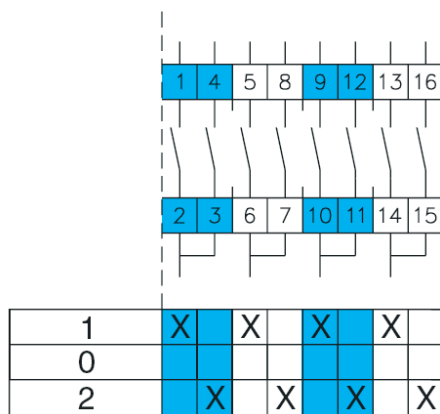

Diagram 4.5.1 Bypass Switch Connections

The AVS contactor isolates the supply voltage from the AVR output circuits but it may be advisable to turn the output circuit breaker off as well. In the by-pass and off modes, the supply is disconnected from the AVR transformers and regulator boards as well as the AVS PCB. However, great care should be exercised as the other terminals and bypass switch connections are still connected to the supply and will be live.

Note: If the AVR is used in bypass mode, a good neutral supply is needed at the input, as this will now be connected to the load and form the load neutral point. (In normal mode, an incoming neutral is not required due to the isolating transformer and delta input configuration of the transformers.)

4.6 Surge Arrester

4.6.1 **Function** - This PCB (ST243) is mounted directly behind the incoming and outgoing terminals on the terminal board. The unit is designed to prevent high voltage spikes and surges from causing damage either to the AVR or to equipment down the line from the AVR. These spikes are commonly caused by lightning, sub-station load switching or heavy motor load switching.

4.6.2 **Operation** - The unit incorporates multi-stage MOV protection circuits. Which is designed to clamp high voltage, high energy spikes from the line or the load. It also incorporated X2 rated mains filter capacitors to filter high frequency noise and slow down fast transient edges that might otherwise cause malfunction of the AVR or the load equipment.

4.7 Suppressor Boards

These small PCBs (ST184) are fitted on the side of the transformers and mount two filter capacitors. The filter noise and fast transient edges on the output connections of the AVR so as to prevent noise from the load from disturbing the correct function of the AVR circuits.

4.8 Fuse Board

There is a small fuse board (ST179) mounted on the terminal board of the AVR. It provides as fused supply to the ventilation fans from the regulated AVR output supply. It also provides a fuse supply for the lines to the three phase AVS PCB.

4.9 Ventilation Fans

In the indoor AVR there are four fans fitted near the top of the enclosure, two on each side. They run continuously and extract warm air from the top of the AVR enclosure. Cool air is drawn in from the ventilation panels lower down the AVR casing.

In the outdoor AVR, there fans mounted under a cover on the door. These perform the same function as for the indoor unit. They draw cool air into the AVR enclosure via ventilation grills lower down at the rear of the enclosure.

4.10 Output Circuit Breaker

This is provided to protect the AVR from overload and short circuit on the output. It can also be used to isolate the load during testing.

4.11 Digital Meters

Some models are fitted with digital meters to show input and output voltage and output current. When fitted to indoor units the meters are fitted on the door, externally visible. When fitted to outdoor units the meters are again fitted to the door but only visible when the door is open.

There are two meters; the upper shows input and out voltage and the lower shows output current. A button is provided to toggle the display from input to output voltage, with an LED indicating which is being displayed (see below).

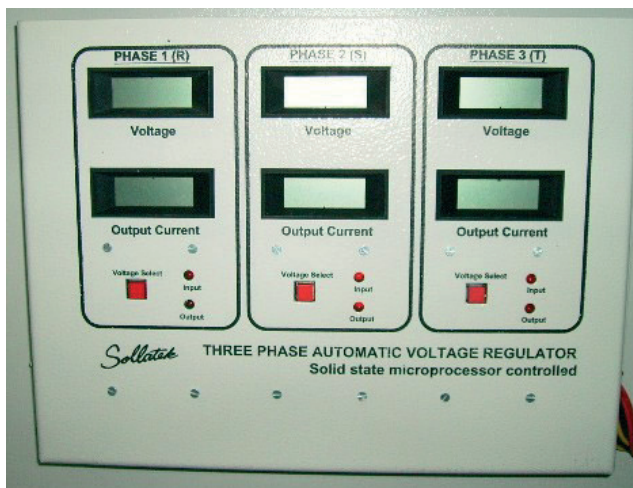

5 Maintenance

This is a fully solid state AVR with no moving parts and therefore requires only the minimum of maintenance. You can expect many years of trouble-free service with the AVR completely unattended.

Isolate the incoming mains supply before carrying out any maintenance.

5.1 Front Access

The front of the AVR enclosure has a hinged, lockable door. This can be opened to view the main power PCBs for the AVR. The indicators on these PCB can then be viewed but care must be taken when opening this door with the power connected.

5.2 Rear Access

On the indoor AVRs, there is a rear access panel which can be removed to gain access to the AVR input and output terminals, in addition to other components. See photo 2.9.1. On the outdoor units, there is no rear access and all parts are accessed via the front door.

Great care should be exercised if power is turned on while the rear door is opened because the live power terminals will be exposed.

5.3 Cover Removal

On the outdoor unit, the AVR cover is of a one piece construction and can not be removed. All components are accessible via the large front access door.

On the indoor units, full access to all components can only be gained by removal of the whole cover of the AVR. To do this proceed as follows:

1. Turn off and isolate the power.

2. Remove the rear access panel.
3. Open the front access door and carefully remove the small plugs from the phase status LEDs. Also remove the ribbon cable from the AVS LED PCB (ST144). Remove this wiring from the inside of the door.
4. Remove the earth wire from inside the door, as well as the earth wires between the case sides and base.
5. Open the door fully and lift it off it's hinged. Place it to one side out of the way.
6. Remove the pull-off connection from the ventilation fans.
7. Loosen and remove the lifting eyes/bolts in the top cover of the AVR.
8. With the help of an assistant, lift the whole cover up and off the AVR to reveal the transformer and circuit boards.
9. Fitting the cover is the reverse process of removal.

5.4 Routine Checks

This is a fully solid state AVR with no moving parts and therefore requires only the minimum of maintenance. You can expect many years of trouble-free service with the AVR completely unattended.

Isolate the incoming mains supply before carrying out any maintenance.

The only maintenance required is to clean any dust and dirt from the outside and inside of the casework which could be restricting the free ventilation of the equipment. There is a ventilation grill to the rear of the outdoor unit that should periodically be cleared of any dust, obstructions or other build-up. If there is a build up of dust on the PCBs then this should also be carefully removed with a soft brush.

It is also wise on any equipment periodically to check the security of the electrical connections and the condition of the cabling. Again ensure the power is turned off before starting work.

Check that all the ventilation fans are functioning correctly.

If the AVR is damaged for any reason, or you suspect a fault, contact your nearest Sollatek agent or Sollatek (UK) Ltd Head office for advice.

6 Troubleshooting

6.1 Safety - Under no circumstances should any work be carried out on the unit unless the supply is isolated.

6.2 False Starting

If it is found that the AVR keeps trying to start but turns off immediately, this is most likely to be due to poor wiring to the AVR or in the building. This could be:

- a) Cabling is not thick enough.
- b) Cabling is too long for its thickness leading to excessive volt drop.
- c) Poor joints or connections.

Any such problems should be corrected, so that the supply can deliver the high currents necessary to run the load.

6.3 Shut Down

If it is found that the unit switches off after some time even when the mains voltage is good, it may be that the AVS is detecting some bad condition of the mains supply that is not apparent without the use of test equipment.

Alternatively, it may be that the temperature overload is operating, in which case the following points should be checked:

- a) The output current is not above that stated on the serial label at the rear of the AVR.
- b) The AVR is not subject to excessive ambient temperature due to a poor location near a source of heat.
- c) The ventilation grills on the side of the AVR case have not been covered or blocked.
- d) That there is room for free movement of air around the outside of the AVR casework.
- e) That all ventilation fans are working correctly and extracting air.

6.4 Common Troubleshooting Points

Problem	Cause/Solution
AVR trips main breaker at switch on.	<ol style="list-style-type: none"> 1. Check that input and output wiring is not shorted out. 2. Check that input circuit breaker is suitable for inductive loads.
AVR shuts down after a period of normal operation.	<ol style="list-style-type: none"> 1. Check that load does not exceed rated output. 2. Check that ventilation ducts/fan outlets are not blocked. 3. Incoming voltage may be too low to drive AVR electronic systems.
AVR shuts down immediately upon switch on.	<ol style="list-style-type: none"> 1. Check terminal joints and connections satisfactorily made. 2. Check incoming cable is of sufficient capacity. 3. Check that cable run not too long causing excessive volt drop.
Input power is present but there is no output.	<ol style="list-style-type: none"> 1. Check that AVS indicators (if fitted) show 'on' (green). If 'red', then voltage on one or more phases is too high or low. If 'yellow', then wait for time delay to finish and output should switch on. 2. Check that circuit breakers (if fitted) are in the 'on' position.
Three phase equipment rotates backwards.	<ol style="list-style-type: none"> 1. Phase rotation problem. Check incoming and outgoing mains wiring 2. Check the bypass switch is set to position 1 (normal) or 2 (bypass)

6.5 Error Indications

If the AVR has shut down it is possible to observe the LEDs on the PCBs within the unit. These can display two different error modes.

This procedure should be carried out by qualified personnel only.

The main door to the unit may be opened whilst the supply is still connected. It is then possible to see the PCBs. There are a number of LEDs visible down one edge of each of the three PCB groups. One of the following two error indications may be observed.

- a) The rectangular LEDs in a group scan in a cyclical pattern starting at the top moving to the bottom repeatedly. This indicates that a fault has occurred in the voltage measurement feedback circuit.

Switch the power off for 10 seconds and switch back on again. If the problem persists check the neutral sense wire on J5 of the ST165/221. Otherwise, contact your nearest Sollatek agent or Sollatek (UK) for advice.

- b) The lower yellow and red under voltage LEDs in the same group flash. This indicates that the AVR has detected an excessively low output voltage error. Switch the power off for 10 seconds and switch back on again. If the problem persists check the neutral sense wire on J5 of the ST165/221. Otherwise, contact Sollatek for advice.
- c) The top red and bottom red rectangular LEDs flash together. This indicates the measurement system has detected a power frequency outside it's specified range. This may be due to high levels of harmonics on the voltage waveform.

These indications may be observed on any or all of the three PCB groups.

7. Parts Replacement Procedure

7.1 AVR On-site Repair Guide

7.1.1 Power PCB replacement procedure (Single PCB per Stack)

Ensure the AVR is isolated from the supply and load before commencing

1. Remove neutral sense cable (Single cable connected to J5)
2. Remove ribbon cable (connected to J2) if fitted.
3. Remove Pink/Grey cables (twisted pair to J6)
4. The PCB is fixed to the metalwork by means of 7 screws into nylon pillars. Removing these gives access to the back of the PCB.
5. Undo the 8 nuts/bolts securing the transformer connections to the rear of the PCB. NB - the order in which these cables are connected should be noted for replacement. The Correct cable colour connections are marked on the PCB.
6. Remove faulty PCB. Ensure that the replacement PCB is exactly the same type as the removed PCB ie slave, master, 3 way, 5 way etc.
7. Fitting replacement PCB is a reversal of the above procedure.
8. It is essential that the On Site AVR Test Procedure following Maintenance/Repair for replaced power PCBs is followed before the AVR is put back on-line.

7.1.2 Power PCB replacement procedure (Multiple PCBs per Stack – see Photo)

Ensure the AVR is isolated from the supply and load before commencing

1. Remove front PCB neutral sense cable (Single cable connected to J5)
2. Remove front PCB ribbon cable (connected to J2)
3. Remove Pink/Grey cables (twisted pair to J6)
4. The front PCB is fixed to those behind by hexagonal brass pillars and nuts. To remove the the front PCB remove these nuts.
5. The same procedure should be repeated until the faulty board is outermost.
6. Replace faulty PCB. If this is the PCB with the transformer cables attached then the above procedure for single PCB per stack should be followed here. Ensure that the replacement PCB is exactly the same type as the removed PCB ie slave, master, 3 way, 5 way etc.
7. Re-assembling the PCB stack is the reverse of this procedure.

8. It is essential that the On Site AVR Test Procedure following Maintenance/Repair for replaced power PCBs is followed before the AVR is put back on-line.

7.1.3 Power Board Parts Identification.

In the larger AVRs the main circuit boards are type ST165. There is one master PCB per phase and possibly several slaves. For instance, in the picture below of an AVR3x400, there is one master and 7 slave PCBs.

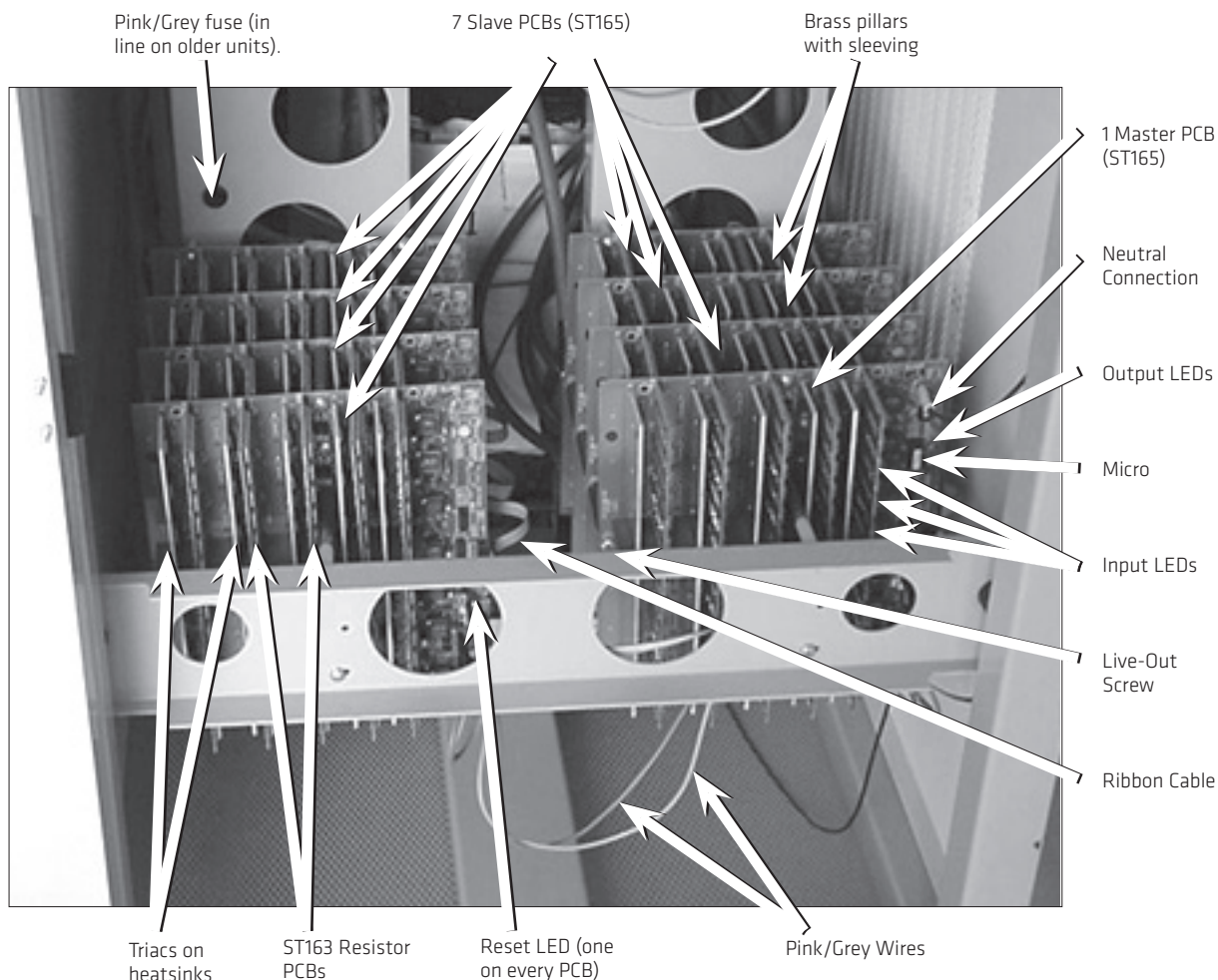

Note

AVRs of 50 amps and below ONLY have ONE power PCB per phase.

1. The Pink/grey wire brings low voltage ac from a small winding on the main transformer to power the circuit boards. It connects first to one PCB, and then links to all the rest.
2. The ribbon cable takes the control signals from the maser PCB and links it to all the slave PCBs.
3. There are seven round input LEDs on each PCB. These should all be on the same position for the PCBs on any one phase.
4. The Reset LED will only be on when the mains power is too low to operate the circuit boards correctly.

7.1.4 AVS PCB replacement procedure

1. Ensure the AVR is isolated from the supply and load before commencing
2. On certain AVR models it will be necessary to remove the rear panel to access the AVS PCB. On outdoor models the AVS (PCB and contactor) is situated within the cabinet, on the terminal panel.
3. Note all wiring colours and positions and AVS settings.
4. Remove all wiring.
5. Remove PCB by undoing screws
6. Place replacement PCB in position and fix.
7. Replace wiring in the same order as previously connected.
8. Ensure all voltage and delay setting knobs are set to the same positions as they were on the old PCB.
9. Test according to instructions in AVR Site Test Procedure
10. Replace back panel

7.1.5 AVS Contactor replacement procedure

Ensure the AVR is isolated from the supply and load before commencing

1. Remove AVR back panel by undoing securing screws, or open door on outdoor units.
2. Note all wiring positions.
3. Remove all wiring.
4. Undo securing bolts carefully. Larger contactors are heavy!
5. Remove old contactor and fix replacement in position.
6. Replace all wiring in the same order as previously connected.
7. Test according to instructions in AVR Site Test Procedure
8. Replace back panel

7.1.6 Surge Arrester PCB ST243 Replacement

Ensure the AVR is isolated from the supply and load before commencing

1. Remove back all casing (see section 5) on an indoor unit. Open front door on an outdoor unit.
2. Remove the terminal board via its mounting bolts. Turn it a little to gain access to the rear where the ST243 PCB is mounted.
3. Remove all the wires from the rear of the terminals. Carefully label and take note of where all wires are connected.
4. Remove the nuts from the terminals and remove the ST243 .
5. Fit a new ST243.
6. Assembly is the reverse of removal, taking care to fit all connection back in the correct place.

7.2 AVR On-site Test Procedures following Maintenance/Repair

7.2.1 Items Required

- 2 off Single Phase Variac (Variable Transformer)
- 2 off Multimeters c/w test leads and clips
- 1 off Clamp-on Current Meter
- 1 off Test lamp

7.2.2 Test Connections for AVR Input Power

To test a single output phase of the AVR it is necessary to supply power to two of the input phase terminals. This is due to the delta input configuration of the transformer feeding a star output configuration. The table below shows which phases must be supplied at the input to test which phase on the output.

Transformer/power PCB	Output Under Test	Supply Inputs
Top	R1	R1 and S2
Middle	S2	S2 and T3
Lower	T3	T3 and R1

The two inputs need to be supplied from two variacs from two different phase of a three phase supply. The neutrals of the variacs need to be connected to the neutral of the supply. However, the neutral input of the AVR need not be connected.

7.2.3 Following Master PCB Replacement

The AVR should be disconnected from Mains and Load before commencing this test.

1. Connect the Variacs inputs to two phases of a three phase mains supply but do not switch on.
2. Connect Test Lamp across Neutral and output of the power pcb ST122/165 of the phase under test.
3. Connect the Variac outputs to the AVR incoming terminals as in the table above.
4. Reduce Variac output voltage settings to zero.
5. Connect Multimeter # 1 (indicating AC Voltage 600V scale) across variac live outputs.
6. Connect Multimeter # 2 (indicating DC 20V scale) between TP1 (0V), and TP2 (5V).
7. Fit clamp-on current meter around one variac live out cable (set to 200A)
8. Switch on power to the variacs and increase output voltage slowly observing current measurement.
9. Current should rise slowly and be no more than a few amps at 100V input (e.g. 1A on a 50A AVR).
10. Set Master PCB Potentiometer P2 fully anti clock wise. Increase variac and check that TP2 reaches about 4.8V and stabilises when the mains reaches about 200V. Reset LED LD8 should be on, as should the green output LED LD13, but no others. Adjust P2 for 5.00Vdc.
11. Move meter positive lead to TP4 (7V). Check this stabilises between 6.8V and 7.2V when the variac is increased to 250V.
12. Continue to increase the variac(s) and the Reset LED (LD8) should go off at approx. 240 to 260V mains in. The green tap LED (LD5) should come on and then move to the end (LD1). Check the lamp on the output comes on.
13. Turn P1 fully clockwise (indicates 240V). Turn the variac to 270V in. Check the output is between 210 and 230V ac and that the end red LED (LD1) is on.

14. Increase the variac until the AVR output is 241Vac +/- 0.5V. SLOWLY turn P1 anti-clockwise until the output voltage drops (to approx. 222V). LED LD2 should now be on.
15. Reduce the variac until LD1 comes back on. SLOWLY increase the variac and check that the AVR output reaches 239 to 241V before dropping. (If not repeat steps 16 and 17 above). Keep increasing the variac and check that the voltage rises and drops in the same way a further 5 times. The round LEDs should move step at a time to the end. Check P1 points to 230V on the PCB ident, +/-5V.
16. Slowly reduce the variac and check the output voltage goes down to 220V before rising again. This should happen a total of 6 times.
17. Increase and decrease the variac several times and check that all LEDs (LD1 to 7) light in turn. Check also that there is no 'thudding' noise made by either the transformer or the variac. (A faint 'click' may be heard from the PCB but this is normal.)
18. Switch the variacs off and remove the neutral connection from J5 on the ST165. Turn the variacs on again and check that the output lamp and green LED (LD5) come on for about 1 second and then go off, followed by the four rectangular LEDs lighting in a scanning pattern.
19. Switch off, reconnect the neutral and switch on. Check the output lamp comes on again.
20. Reduce the variac and check the output switches off at 225 to 234 V input.
21. Switch off and disconnect all mains power
22. Repeat the above procedure for the other phases if required.
23. The AVR is now ready for re-connection on-line.

7.2.4 Following Slave PCB Replacement

The AVR should be disconnected from Mains and Load before commencing this test.

1. Connect the Variacs inputs to a mains supply but do not switch on.
2. Connect Test Lamp across Neutral and output of the power pcb ST122/ST165 of the phase under test.
3. Connect the Variac outputs to the AVR incoming terminals as in the table above.
4. Reduce Variac output voltage settings to zero.
5. Connect Multimeter # 1 (indicating AC Voltage 600V scale) across variac live outputs.
6. Fit clamp-on current meter around one variac live out cable (set to 200A)
7. Vary input volts between 270 and 490V a number of times to ensure the replaced PCB is functioning properly. Lamp on output should be lit.
8. Leave on soak test for 1 hour.
9. Switch off and disconnect all input and output connections.
10. The AVR is now ready for re-connection on-line

7.2.5 Automatic Voltage Switcher (AVS) function check

The AVR should be disconnected from Mains and Load before commencing this test.

NB This is a complicated procedure and should only be attempted by a qualified electrician

1. Connect two incoming phases of the mains supply in the normal way.
2. Connect a variac to a mains supply, running from the third phase.
3. Connect a light bulb to the output of any phase.
4. Switch on the first two phases. The red LED on the AVS should be lit.
5. Set the variac to 230V and switch on.
6. Time the delay before the AVS switches on (the light bulb lights). This is the time delay, which can be adjusted on the AVS PCB using the DELAY pot. The green LED should be on.
7. Increase variac voltage until the AVS cuts out. The red high voltage LED should be on. The voltage at the input to the AVS should be around 260V. This can be adjusted on the AVS PCB using the HIGH V pot.
8. Decrease the variac voltage to 230V. The high amber LED should be on. Wait until the AVS switches back on.
9. Further decrease the variac voltage until the AVS cuts out again. The voltage at the input to the AVS should be around 190V. This can be adjusted on the AVS PCB using the LOW V pot.
10. Increase the variac voltage to 230V. The low amber LED should be on.
11. After the wait time the AVS should reconnect.
12. This concludes the AVS test.

Final Test Procedure**Document Number: QP07****Product Name: Installed Large AVR****Variants: All ST165 based**

Inspection Checklist

1. Check PCBs for damage, poor alignment, comb positioning and general condition.
2. Ensure that all internal nuts, bolts and fixings are secure and that nothing has come loose during installation.
3. Examine all wiring, paying particular attention to power cable terminal tightness. If Bypass is fitted, check all power connections. Check crimp joints have not loosened. Check all pink/grey connections are correct and that ribbon cable connectors have not been dislodged.
4. Clean all exterior panel work and check for damage.

Function Test

1. Note all results on form QF07.
2. Using a variac on input of one phase at a time, with a test lamp at the output, increase voltage until ST165 master switches on (reset LED goes off). Note input voltage. This should be in the range 140V to 170V.
3. Reduce input voltage and note voltage at which reset LED lights. This should be between 120V and 135V.
4. Increase input voltage from 160V and note output voltage at which tap down occurs on each tap. This should be at 240V +/- 1V.
5. From 270V reduce input voltage and note output voltage at which tap up occurs on each tap. This should be at 220V +/- 1V.
6. Set output voltage to 220V on brown tap. Input voltage should be less than 161V.
7. Set output voltage to 240V on violet tap. Input voltage should be greater than 280V.
8. Set input voltage to 230V. Compare measured input voltage to displayed input voltage. Difference should not exceed 2%.
9. Compare measured output voltage to displayed output voltage. Difference should not exceed 2%. AVS must be operational for this test.
10. Compare measured output current to displayed output current. Difference should not exceed +/- 10% at 20% full load. AVS must be operational for this test.
11. Connect two phases to the input of the AVR. Connect the third phase via the variac. Adjust the variac voltage to 230V. Time the delay before AVS switches on. This should 10 seconds +/- 5%. Ensure AVS amber LED illuminates during wait.
12. Increase variac voltage until AVS cuts out. Note AVS input voltage. This should be 260V +/- 3 V. Ensure Red overvoltage LED is illuminated.
13. Reduce input voltage to 230V. Ensure AVS amber LED is illuminated. Once AVS has re-connected reduce input voltage until AVS cuts out. Note AVS input voltage. This should be 190V +/- 3 V. Ensure red undervoltage LED is illuminated.
14. Note AVS HVD, LVD and Time delay settings.

Inspection and Test

Document Number: QF07

Product Name: Installed Large AVR

Variants: All ST165 based

Inspection Checklist

1. PCBs
2. Assembly
3. Wiring
4. Exterior

Function Test

Tick for pass and enter value

	R1 (value)	S2 (value)	T3 (value)	Limit
Switch on voltage	<input type="checkbox"/> ----	<input type="checkbox"/> ----	<input type="checkbox"/> ----	140V - 170V
Switch off voltage	<input type="checkbox"/> ----	<input type="checkbox"/> ----	<input type="checkbox"/> ----	120V - 135V
Tap down voltage	<input type="checkbox"/> ----	<input type="checkbox"/> ----	<input type="checkbox"/> ----	240+/-1V
Tap up voltage	<input type="checkbox"/> ----	<input type="checkbox"/> ----	<input type="checkbox"/> ----	220+/-1V
I/P V @ 220V out (brown)	<input type="checkbox"/> ----	<input type="checkbox"/> ----	<input type="checkbox"/> ----	< 161V
I/P V @ 240V out (violet)	<input type="checkbox"/> ----	<input type="checkbox"/> ----	<input type="checkbox"/> ----	> 280V
I/P V meter % acc.	<input type="checkbox"/> ----	<input type="checkbox"/> ----	<input type="checkbox"/> ----	+/- 2%
O/P V meter % acc.	<input type="checkbox"/> ----	<input type="checkbox"/> ----	<input type="checkbox"/> ----	+/- 2%
Current meter % acc.	<input type="checkbox"/> ----	<input type="checkbox"/> ----	<input type="checkbox"/> ----	+/- 10%
AVS Switch on time	_____			3 min +/- 5%
AVS HVD operates	_____			190V +/- 3V
AVS LVD operates	_____			260V +/- 3V
AVS LED function	_____			
AVS HVD setting	_____			
AVS LVD setting	_____			
AVS delay setting	_____			

Inspected by (SUKL Engineer) _____

Accepted by (Facilities Engineer) _____

Date _____

8. Specifications

Model	: Three Phase Automatic Voltage Regulator
Input voltage	: 230/400V +22% -30% (Other voltages available)
Output voltage	: 230/400V +/- 4% (Other voltages available)
Correction time	: within 15 m sec
Frequency range	: 45Hz to 88Hz
Voltage protection	: Automatic under voltage protection
THD	: < 0.25%
Max. amb. Temp.	: 40 C
Acoustic Noise	: < 45 dB
Expected Service Life	: > 25 years
Technology	: All solid state (static) switching
Bypass modes	: Manual bypass - Mains direct to output
Filtering	: Input and output noise and spike filtered
Attenuation Ratio	: 10:1
IP Rating	: Indoor Unit - IP21 : Outdoor Unit - IP44
Standards	: Manufactured to comply with :- EN60065 EN60555 BSEN50081 BSEN50082
Weight & Dimension	: See opposite

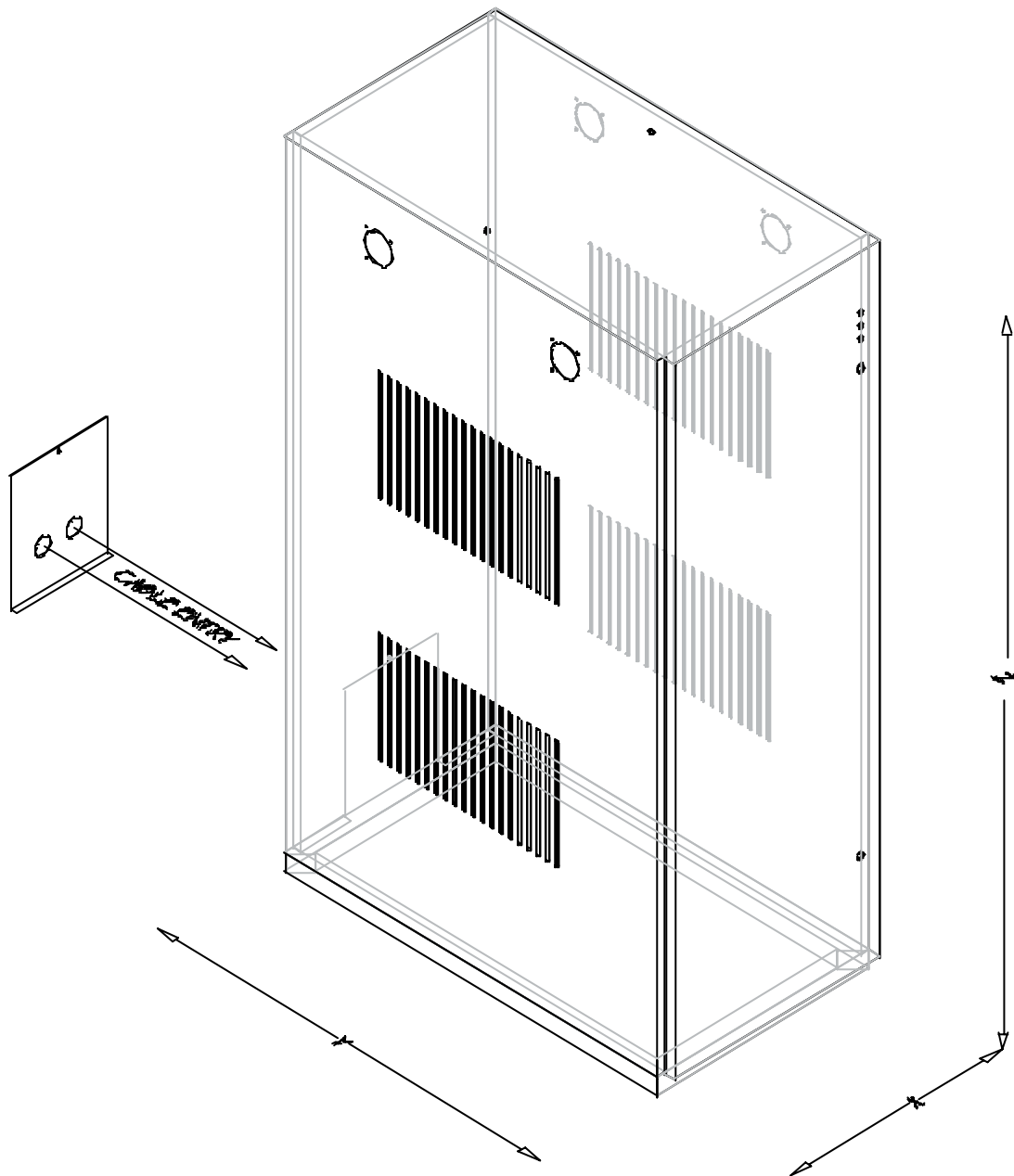

Model	Weight	Dims (mm)
	kg	W x D x H
AVR3x12-22-IO	450	500 x 835 x 1280
AVR3x20-22-IO	575	680 x 1200 x 2070
AVR3x30-22-IO	675	680 x 1200 x 2070
AVR3x50-22-IO	735	680 x 1200 x 2070
AVR3x75-22-IO	790	680 x 1200 x 2070
AVR3x100-22-IO	1200	1360 x 1200 x 2070
AVR3x150-22-IO	1590	1360 x 1200x 2070

Appendix 2 - AVR Fault Report

Please fill in as much information as possible when reporting a fault with an AVR. This will help to generate accurate records and also help to solve any problems as quickly and fully as possible.

When complete, please fax to Sollatek +44 (1753) 214 580 or email to support@sollatek.com

Company Name and Address:	AVR Site Location:
Report Date:	Engineer

AVR Type/Size:	Serial Number:		
Nominal Voltage	Date Connected		
Circuit Breaker Ratings; Input:	Output:		
AVR Options:			
Analogue Meters:	Yes / No	AVS	Yes / No
Digital Meters:	Yes / No	DSPs	Yes / No
By-pass Switch:	Yes / No		

Description of Problem:

Description should include the following information:

- What type of load was connected at the time of the fault? Also current rating of load.
- An indication of the mains voltage levels and condition at the time of fault i.e. dip in voltage or complete failure.
- Any other factors that may help us pinpoint the fault.
- Did AVR fault occur immediately after power on or at a later time?

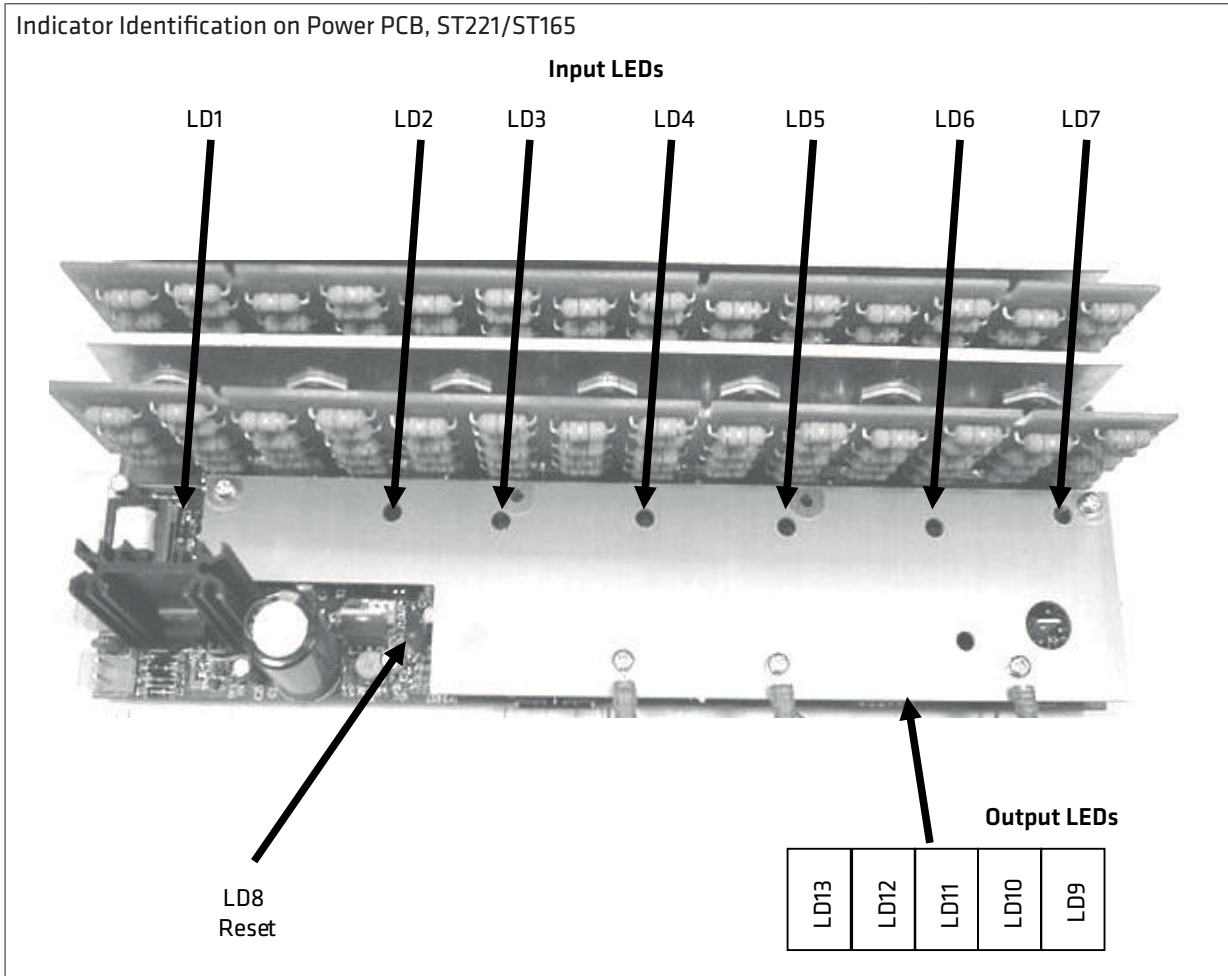

Which PCB Indicators are on?	Top (R1)	Middle (S2)	Bottom (T3)
Input LEDs (round) On master PCB			
O/P LEDs (square) On master PCB			
Reset LED (LD8) On master PCB			
AVS LEDs (on AVR PCB or front door panel)			

PCB version details if can be seen	Top (R1)	Middle (S2)	Bottom (T3)
PCB ST number Shown on edge of circuit board	ST	ST	ST
Software Version shown on white label on micro chip on master PCB			

Voltages - Line to Neutral	Top (R1)	Middle (S2)	Bottom (T3)
Input to AVR On rear terminals			
Output of AVR On PCB Live-out terminals			
Input of AVS Input terminals of contactor			
Output of AVS On rear AVR terminal			

Voltages Line to Line	R1 - S2	S2 - T3	T3 - R1
Input to AVR			
Output of AVR			
Input of AVS			
Output of AVS			

Please provide any relevant extra information or more detail on extra sheets.



SOLLATEK UK LTD.

Tel: +44 (1753) 214 500
sales@sollatek.com
www.sollatek.com

Sollatek (UK) Ltd. Sollatek House, Waterside Drive, Langley, Slough SL3 6EZ UK

ISO9001: 2015 accredited company

All weights and dimensions are approximate. Specifications are subject to change without prior notice. ©Sollatek (UK) Limited 2019. All Rights Reserved. SOLLATEK and the SOLLATEK device are the trade marks of the Sollatek group of companies.

MJA	10/04/2019
-----	------------